

T2 PRECISION ROTARY TORQUE TRANSDUCER (U.S. & METRIC)

FEATURES & BENEFITS

- Capacities from 0.1 to 20K Nm (0.88 to 177K lbf-in)
- Speed up to 15K RPM
- ± 5 VDC output
- 12-28 VDC supply
- Contactless data transmission
- Digital electronics with on-shaft shunt
- 0.1% combined error
- 10 kHz sample rate
- 16-bit resolution
- Very short overall length

SPECIFICATIONS

ACCURACY – (MAX ERROR)		
Combined Error – %FS		± 0.1
Nonrepeatability – %FS		± 0.02
Resolution – bit		16
TEMPERATURE		
Effect on Zero – %RO / deg	$^{\circ}\text{C}$	± 0.02
Effect on Output – % / deg	$^{\circ}\text{C}$	± 0.01
Compensated Range	$^{\circ}\text{C}$	+5 to +45
	$^{\circ}\text{F}$	+41 to +113
Operating Range	$^{\circ}\text{C}$	0 to +60
	$^{\circ}\text{F}$	+32 to +140
Storage Range	$^{\circ}\text{C}$	-10 to +70
	$^{\circ}\text{F}$	+14 to +158
ELECTRICAL		
Supply Voltage – VDC		12 - 28
Supply Current – mA		≤ 60
Output – VDC		± 5
Bandwidth, Hz (-3dB)		1,000
Sample Rate – Hz		10,000
Calibration Signal – %FS		100
Electrical Connection		12-pin binder series 581 (Includes mate)
ENCODER OPTION		
Capacities	0.1 - 1K Nm	360 pulse/rev, 2-track, +5V TTL, 90° offset, quadrature encoder
	0.88 - 8.85K lbf-in	
	2K - 20K Nm	60 pulse/rev, 1-track, +5V TTL
	17K - 177K lbf-in	
MECHANICAL		
Safe Overload – %RO		200
Max Speed – RPM		Varies with Capacity (see table)
Shaft Material		Alloy steel
Housing Material		Aluminum

STANDARD CONFIGURATION



MODEL T2 (Shown)

OPTIONS

- Speed and angle output – 360 Pulse TTL, 2-Tracks 90° offset, available on capacities up to 5K Nm (44.25K lbf-in) only
- +10V Torque Output
- RS485
- Keyed shafts – per DIN 6885.1
- $\pm 0.05\%$ combined error
- Mating cable assembly
- Speed output - 60 Pulse TTL, 1-Track, available on capacities 10K Nm (88.5K lbf-in) and above

T2 PRECISION ROTARY TORQUE TRANSDUCER (U.S. & METRIC)

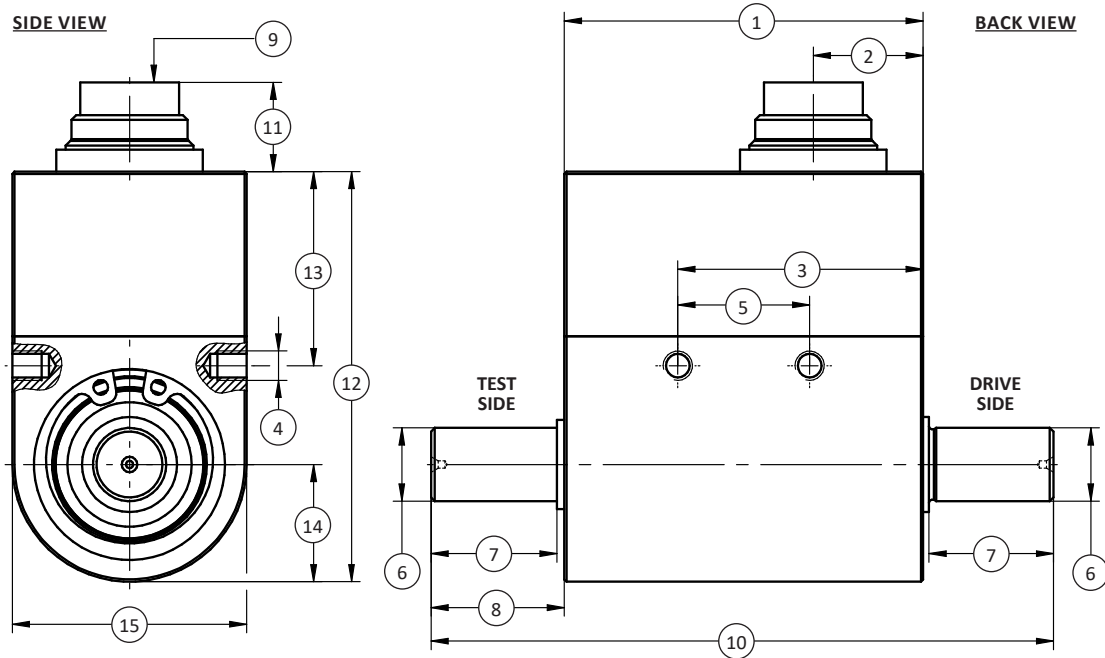

DIMENSIONS

See Drawing	CAPACITIES			
	Metric (Nm)	U.S. (lbf-in)	Metric (Nm)	U.S. (lbf-in)
	0.1, 0.2, 0.5, 1, 2, 5	0.88, 1.77, 4.43, 8.85, 17.7, 44.3	10	88.5
	mm	in	mm	in
(1)	49	1.9	49	1.9
(2)	15	0.6	15	0.6
(3)	33.5	1.32	33.5	1.32
(4)	M4 ↓ 4	M4 ↓ 0.2	M4 ↓ 4	M4 ↓ 0.2
(5)	18	0.7	18	0.7
(6)	∅8g6	∅0.3148 / 0.3144	∅10g6	∅0.3935 / 0.3931
(7)	17	0.67	17	0.67
(8)	18	0.7	18	0.7
(9)	Connector 12-pin		Connector 12-pin	
(10)	85	3.35	85	3.35
(11)	12	0.5	12	0.5
(12)	56	2.2	56	2.2
(13)	26.5	1.04	26.5	1.04
(14)	16	0.6	16	0.6
(15)	32	1.3	32	1.3

T2 PRECISION ROTARY TORQUE TRANSDUCER (U.S. & METRIC)

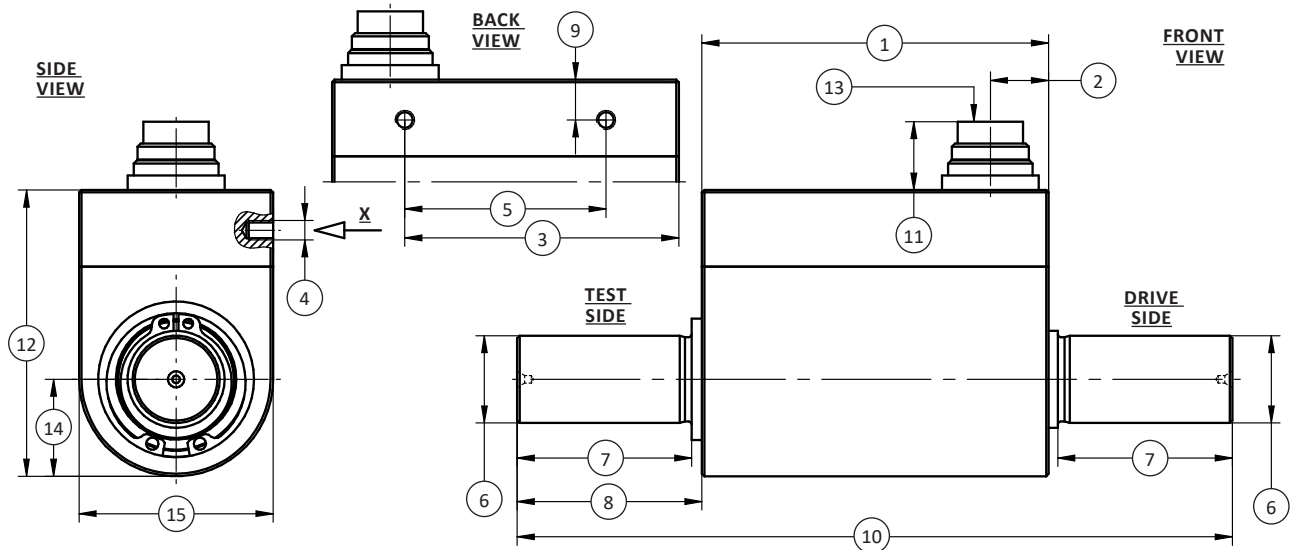

DIMENSIONS (CONTINUED)

See Drawing	CAPACITIES					
	Metric (Nm)	U.S. (lbf-in)	Metric (Nm)	U.S. (lbf-in)	Metric (Nm)	U.S. (lbf-in)
	20, 30	177, 265	50, 100	443, 885	200, 500	1.77K, 4.43K
	mm	in	mm	in	mm	in
(1)	71.5	2.81	71.5	2.81	72.5	2.85
(2)	12	0.5	12	0.5	15	0.6
(3)	56.5	2.2	56.5	2.2	51.5	2.03
(4)	M4 ↓ 5	M4 ↓ 0.2	M4 ↓ 5	M4 ↓ 0.2	M4 ↓ 6	M4 ↓ 0.2
(5)	41.5	1.63	41.5	1.63	29.5	1.16
(6)	∅18g6	∅0.7087 / 0.7082	∅18g6	∅0.7087 / 0.7082	∅32g6	∅1.2595 / 1.2589
(7)	18	0.71	36	1.42	38	1.50
(8)	20	0.79	38	1.50	43.5	1.71
(9)	8.3	0.33	8.3	0.33	8.3	0.33
(10)	111.5	4.39	147.5	5.81	159.5	6.28
(11)	14	0.6	14	0.6	14	0.6
(12)	59	2.32	59	2.32	76	2.99
(13)	Connector 12-pin		Connector 12-pin		Connector 12-pin	
(14)	20	0.79	20	0.79	29	1.14
(15)	40	1.57	40	1.57	58	2.28

T2 PRECISION ROTARY TORQUE TRANSDUCER (U.S. & METRIC)

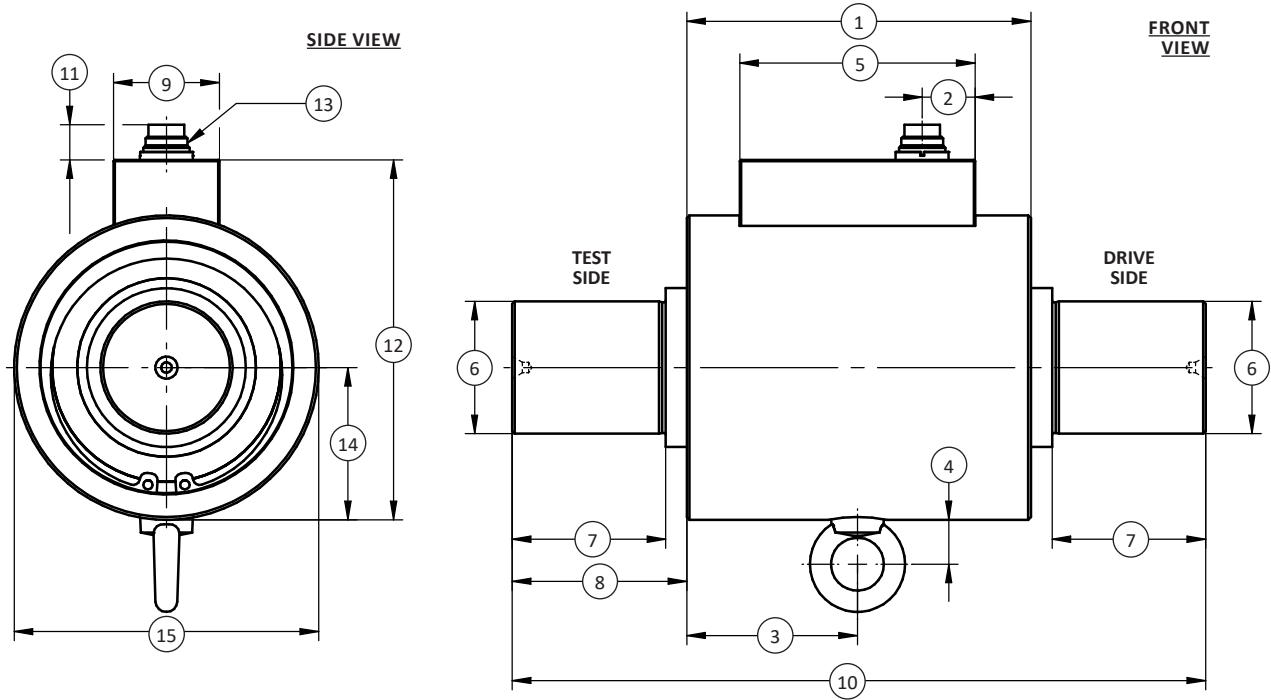

DIMENSIONS (CONTINUED)

See Drawing	CAPACITIES					
	Metric (Nm)	U.S. (lbf-in)	Metric (Nm)	U.S. (lbf-in)	Metric (Nm)	U.S. (lbf-in)
	mm	in	mm	in	mm	in
(1)	130	5.12	135	5.31	190	6.70
(2)	20	0.8	20	0.8	20	0.8
(3)	64.5	2.54	67.5	2.66	95	3.7
(4)	17	0.7	17	0.7	17	0.7
(5)	89	3.5	89	3.5	89	3.5
(6)	Ø50g6	Ø1.9685 / 1.9675	Ø70g6	Ø2.7559 / 2.7547	Ø110g6	Ø4.3307 / 4.3293
(7)	58	2.28	110	4.33	120	4.72
(8)	66	2.60	121	4.76	140	5.51
(9)	40	1.6	40	1.6	40	1.6
(10)	262	10.3	377	14.8	470	18.5
(11)	13	0.5	13	0.5	13	0.5
(12)	136	5.4	161	6.3	233	9.2
(13)	Connector 12-pin		Connector 12-pin		Connector 12-pin	
(14)	57.5	2.26	69.5	2.74	105	4.1
(15)	Ø115	Ø4.5	Ø139	Ø5.5	Ø210	Ø8.3

T2 PRECISION ROTARY TORQUE TRANSDUCER (U.S. & METRIC)

PERFORMANCE PARAMETERS

CAPACITY		MAX RPM	SPRING RATE	MOMENT OF INERTIA ¹		MAX THRUST LOAD ²		MAX SHEAR LOAD ²	
Nm	lbf-in			NM/rad	Drive Side	Test Side	N	lbf	N
0.1	0.88	15,000	1.8x10 ¹	1.9x10 ⁻⁶	2.8x10 ⁻⁷	42	9.44	0.9	0.20
0.2	1.77	15,000	1.8x10 ¹	1.9x10 ⁻⁶	2.8x10 ⁻⁷	58	13.0	1.2	0.27
0.5	4.43	15,000	1.2x10 ²	1.9x10 ⁻⁶	2.8x10 ⁻⁷	172	38.7	1.9	0.43
1	8.85	15,000	1.2x10 ²	1.9x10 ⁻⁶	2.8x10 ⁻⁷	227	51.0	2.9	0.65
2	17.7	15,000	3.6x10 ²	1.9x10 ⁻⁶	2.9x10 ⁻⁷	348	78.2	5.5	1.24
5	44.3	15,000	4.0x10 ²	1.9x10 ⁻⁶	2.9x10 ⁻⁷	650	146	14	3.15
10	88.5	15,000	9.3x10 ²	2.1x10 ⁻⁶	3.8x10 ⁻⁷	1K	225	26	5.85
20	177	15,000	4.5x10 ³	1.2x10 ⁻⁵	9.9x10 ⁻⁶	1.68K	378	43	9.67
30	265	15,000	4.5x10 ³	1.2x10 ⁻⁵	9.9x10 ⁻⁶	2.2K	495	65	14.6
50	443	15,000	8.5x10 ³	1.3x10 ⁻⁵	1.2x10 ⁻⁵	3.1K	697	80	18.0
100	885	12,000	8.5x10 ³	1.3x10 ⁻⁵	1.2x10 ⁻⁵	4.8K	1.08K	160	36.0
200	1.77K	10,000	6.7x10 ⁴	1.0x10 ⁻⁴	9.0x10 ⁻⁵	8K	1.80K	290	65.2
500	4.43K	10,000	7.1x10 ⁴	1.0x10 ⁻⁴	9.0x10 ⁻⁵	14K	3.15K	700	157
1K	8.85K	8,000	3.1x10 ⁵	1.6x10 ⁻³	1.1x10 ⁻³	23K	5.17K	900	202
2K	17K	5,500	7.2x10 ⁵	5.3x10 ⁻³	4.3x10 ⁻³	33K	7.42K	1.2K	270
5K	44.3K	5,500	8.0x10 ⁵	5.4x10 ⁻³	4.3x10 ⁻³	57K	12.8K	2.8K	629
10K	85.5K	5,000	3.1x10 ⁶	4.0x10 ⁻²	3.7x10 ⁻²	90K	20.2K	4.4K	989
20K	177K	5,000	3.7x10 ⁶	4.0x10 ⁻²	3.8x10 ⁻²	130K	29.2K	8.2K	1.84K

Notes:
1 = Without encoder option
2 = Unsupported shaft

ELECTRICAL CONNECTION

Pin	12-PIN ELECTRICAL CONNECTION		12-PIN RS485 OPTION	
	Function	Description	Function	Description
A	NC	-	NC	-
B	Option Angle B	TTL	Option Angle B	TTL
C	Signal (+)	±5 VDC (±10 VDC)	NC	-
D	Signal (GND)	0 VDC	NC	-
E	Supply (GND)	0 VDC, TTL	Supply (GND)	0 VDC
F	Supply (+)	12-28 V	Supply (+)	12-28 VDC
G	Option Angle A	TTL	Option Angle A	TTL
H	NC	-	NC	-
J	NC	-	RS485 Option	RS485 (B)
K	Cal. Control	L < 2.0 V / H > 3.5 V	NC	-
L	NC	-	RS485 Option	RS485 (A)
M	Housing	-	Housing	-