

SML LOW HEIGHT LOAD CELL (U.S. & METRIC)

SPECIFICATIONS

ACCURACY – (MAX ERROR)				
U.S. (lbf)	Metric (N)	Nonlinearity – %FS		Hysteresis – %FS
5 - 300	22 - 1.3K	±0.05		±0.05
500 - 1K	2.2K - 4.5K	±0.10		±0.10
2K	9K	±0.20		±0.10
Nonrepeatability – %RO				±0.03
Creep, in 20 min – %				±0.05
TEMPERATURE				
Compensated Range	°F	0 to +150		
	°C	-15 to +65		
Operating Range	°F	-65 to +200		
	°C	-55 to +90		
Effect on Output – % / deg	°F	±0.0008		
	°C	±0.0015		
Effect on Zero – %RO / deg	°F	±0.005		
	°C	±0.009		
ELECTRICAL				
Rated Output – mV/V (Nominal)		2.0		
Zero Balance – %RO		±1.0		
Bridge Resistance – Ohm (Nominal)		350		
Excitation Voltage – VDC MAX		15		
Insulation Resistance – Megohm		> 5000		
MECHANICAL				
Calibration		Tension		
Safe Overload – %CAP	5 - 10 lbf	800		
	22 - 45 N			
	25 - 2K lbf	150		
	110 - 9K N			
NATURAL FREQUENCY/DEFLECTION				
U.S. (lbf)	Metric (N)	Deflection		Natural Frequency (Hertz)
		in	mm	
5 - 10	22 - 45	0.005	0.13	3000
25	110	0.004	0.09	2500
50	220	0.003	0.08	3300
100	450	0.003	0.08	5000
200 - 300	900 - 1.3K	0.003	0.08	4500
500 - 1K	2200 - 4.5K	0.003	0.08	1800
2K	9K	0.004	0.09	1800
Material	5 - 300 (lbf)	Aluminum		
	22 - 1.3K (N)			
	500 - 2K (lbf)	Stainless Steel		
	2.2K - 9K (N)			

STANDARD CONFIGURATION



Model SML-200 (Shown)

FEATURES & BENEFITS

- Proprietary Interface temperature comp. strain gages
- From 0.75 in (19mm) high
- Performance to 0.05%
- Low extraneous load sensitivity
- Overload protection, SML-5 and SML-10 (SML-22N and SML-45N)

OPTIONS

- Cable length
- Standardized output
- Custom calibration
- Transducer Electronic Data Sheet (TEDS)
- Add connector to cable
- Special temperature range

ACCESSORIES

- Instrumentation

International System of Units (SI) dimensions and capacities are provided for conversion only. Standard products have U.S. capacities and dimensions. SI capacities available upon special request and at an additional cost.

SML LOW HEIGHT LOAD CELL (U.S. & METRIC)

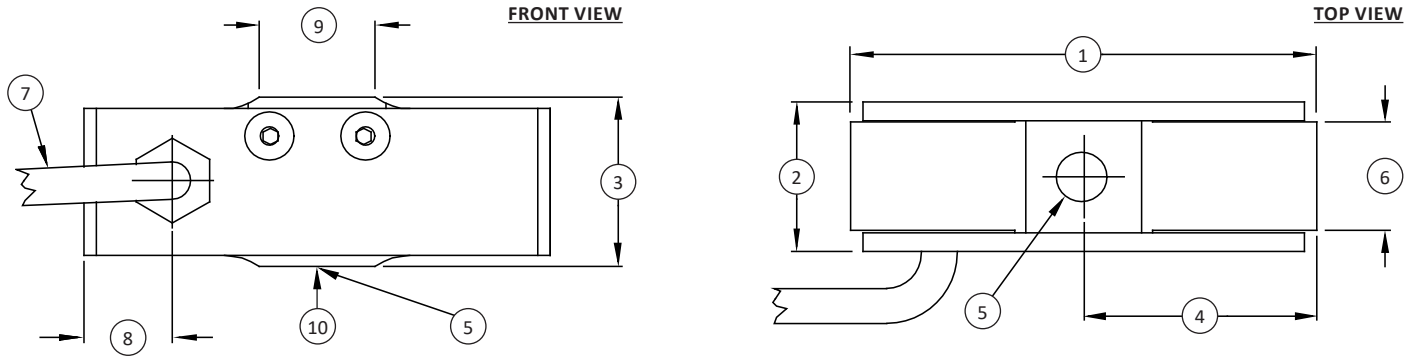

DIMENSIONS

See Drawing	CAPACITY							
	U.S. (lbf)	Metric (N)	U.S. (lbf)	Metric (N)	U.S. (lbf)	Metric (N)	U.S. (lbf)	Metric (N)
	in	mm	in	mm	in	mm	in	mm
(1)	1.80	45.7	2.00	50.8	2.12	53.8	2.80	71.1
(2)	0.52	13.1	0.64	16.3	0.89	22.6	1.16	29.6
(3)	0.73	18.5	0.73	18.5	0.98	24.8	1.24	31.5
(4)	0.90	22.9	1.00	25.4	1.06	26.9	1.40	35.6
(5)	10-32 UNF-2B ↓ 0.20	M5x0.8-6H ↓ 5.0	¼-28 UNF-2B ↓ 0.25	M6x1-6H ↓ 6.0	⅜-24 UNF-2B ↓ 0.38	M8x1.25-6H ↓ 8.0	½-20 UNF-2B ↓ 0.49	M12x1.75-6H ↓ 12.0
(6)	0.34	8.6	0.46	11.8	0.71	18.1	1.00	25.5
(7)	0.13	3.3	0.13	3.3	0.13	3.3	0.13	3.3
(8)	0.29	7.4	0.38	9.7	0.46	11.7	0.75	19.0
(9)	0.50	12.7	0.50	12.7	0.57	14.5	0.77	19.6
(10)	Live end							