

SMA SERIES MINI S-TYPE LOAD CELL (U.S. & METRIC)

FEATURES & BENEFITS

- Proprietary Interface temperature compensated strain gages
- Performance to 0.05%
- Small compact design
- Tension & compression

SPECIFICATIONS

ACCURACY - (MAX ERROR)		
Nonlinearity – %FS		±0.05
Hysteresis – %FS		±0.05
Nonrepeatability – %RO		± 0.02
Creep, in 20 min – %		± 0.05
TEMPERATURE		
Compensated Range	°F	+15 to +115
	°C	-10 to +45
Operating Range	°F	-65 to +200
	°C	-55 to +90
Effect on Output – % /deg	°F	±0.0008
	°C	±0.0014
Effect on Zero – % RO / deg	°F	±0.005
	°C	±0.009
ELECTRICAL		
Rated Output – mV/V (Nominal)		2.5
Zero Balance – %RO		-0.6 to 0.0
Bridge Resistance – Ohm (Nominal)		350
Excitation Voltage – VDC MAX		15
Insulation Resistance – Megohm		>5000
MECHANICAL		
Calibration		Tension
Safe Overload – %CAP		150
Material		Aluminum

OPTIONS

- Cable length
- Standardized output
- Custom calibration
- Add connector to cable
- Special temperature range
- Transducer Electronic Data Sheet (TEDS)

ACCESSORIES

- Instrumentation

CONNECTOR OPTIONS

- 1.5 m (5 ft) integral cable

International System of Units (SI) dimensions and capacities are provided for conversion only. Standard products have U.S. capacities and dimensions. SI capacities available upon special request and at an additional cost.

STANDARD CONFIGURATION

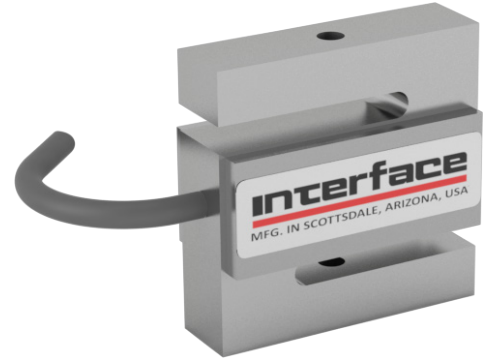

Model SMA (Shown)

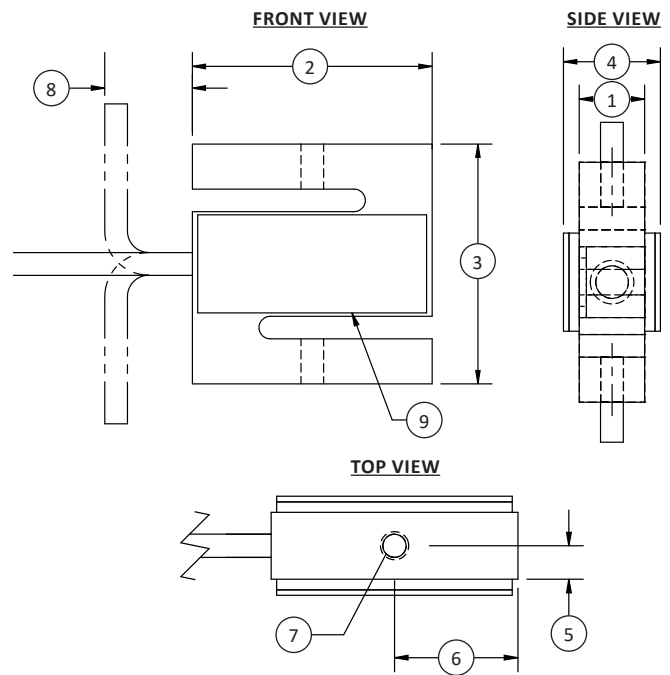

DIMENSIONS

See Drawing	CAPACITY	
	U.S. (lbf)	Metric (N)
	15, 25, 50, 100, 150, 200	60, 500, 600, 900
	in	mm
(1)	0.38	9.5
(2)	1.38	35
(3)	1.38	35
(4)	0.56	14.2
(5)	0.19	4.8
(6)	0.69	17.5
(7)	#10-32 UNF – 2B	M4 X 0.7 – 6
(8)	0.5	12.7
(9)	Identification label	