

- Spring System
- Potentiometric Measuring
- Between 10 mm to 150 mm Electrical Ranges
- High Resolution
- Very Long Life Up To 100 Million Movements
- High Operating Speed 5 m/s
- Small Sizes

LFR series is the industry proven system on both actuator shaft and spring.

LFR is a high precision potentiometric industrial linear motion transducer with a long lasting conductive track suitable for absolute position measuring in control measurement applications.

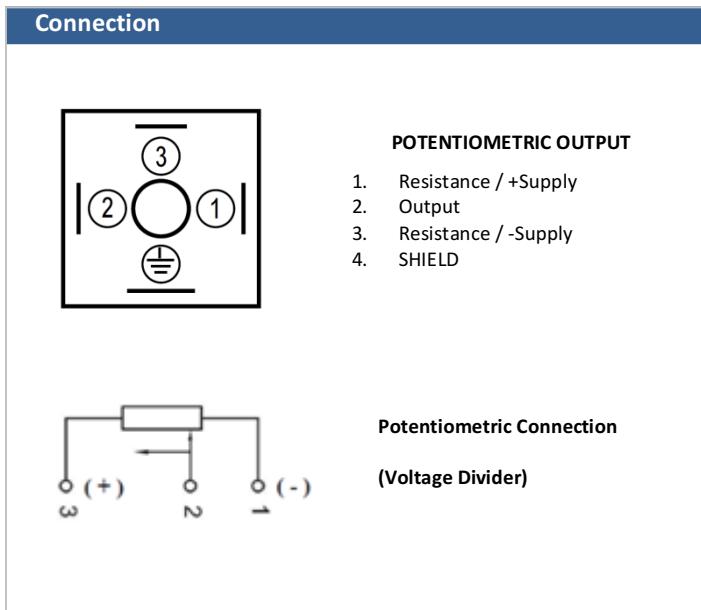

Technical Specifications	
Defined Electrical Ranges (mm)	10 – 25 – 50 – 75 – 100 - 150
Resistance Element	Conductive Plastic
Output Signals	Potentiometric
Independent Linearity	± %0,6
Electrical Connection	4 pin female DIN43650
Power Supply	Maximum 42 VDC
Resistance	5K – 10 K ±%20 (Optional Other)
Operating Temperature	-30°C +100°C
Life	100 Million Movements
Rod Material	Stainless Steel
Housing Material	Anodized Aluminum

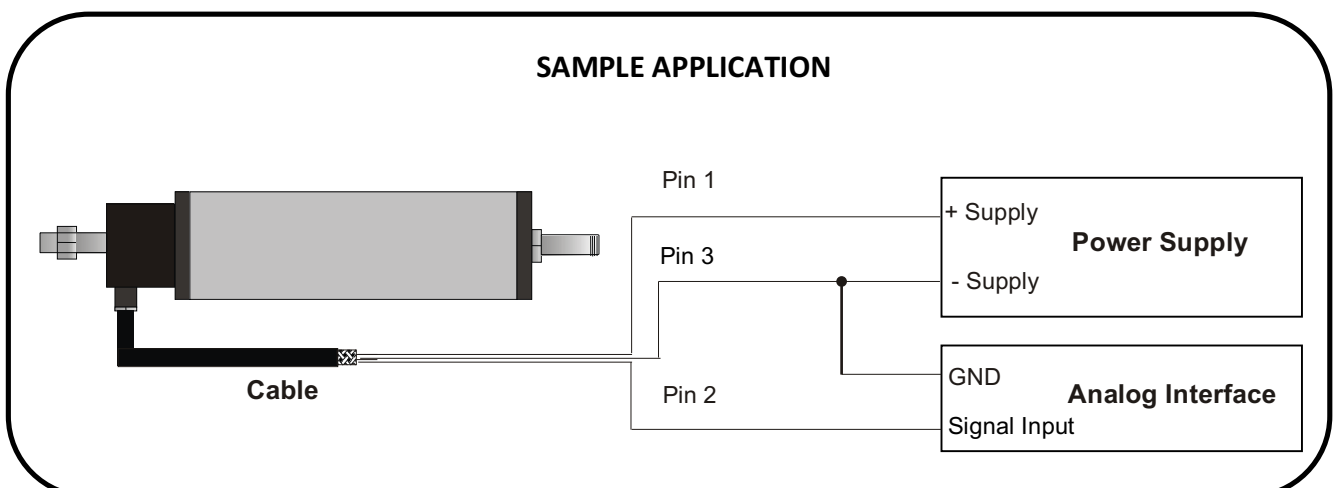

Mechanical Dimensions

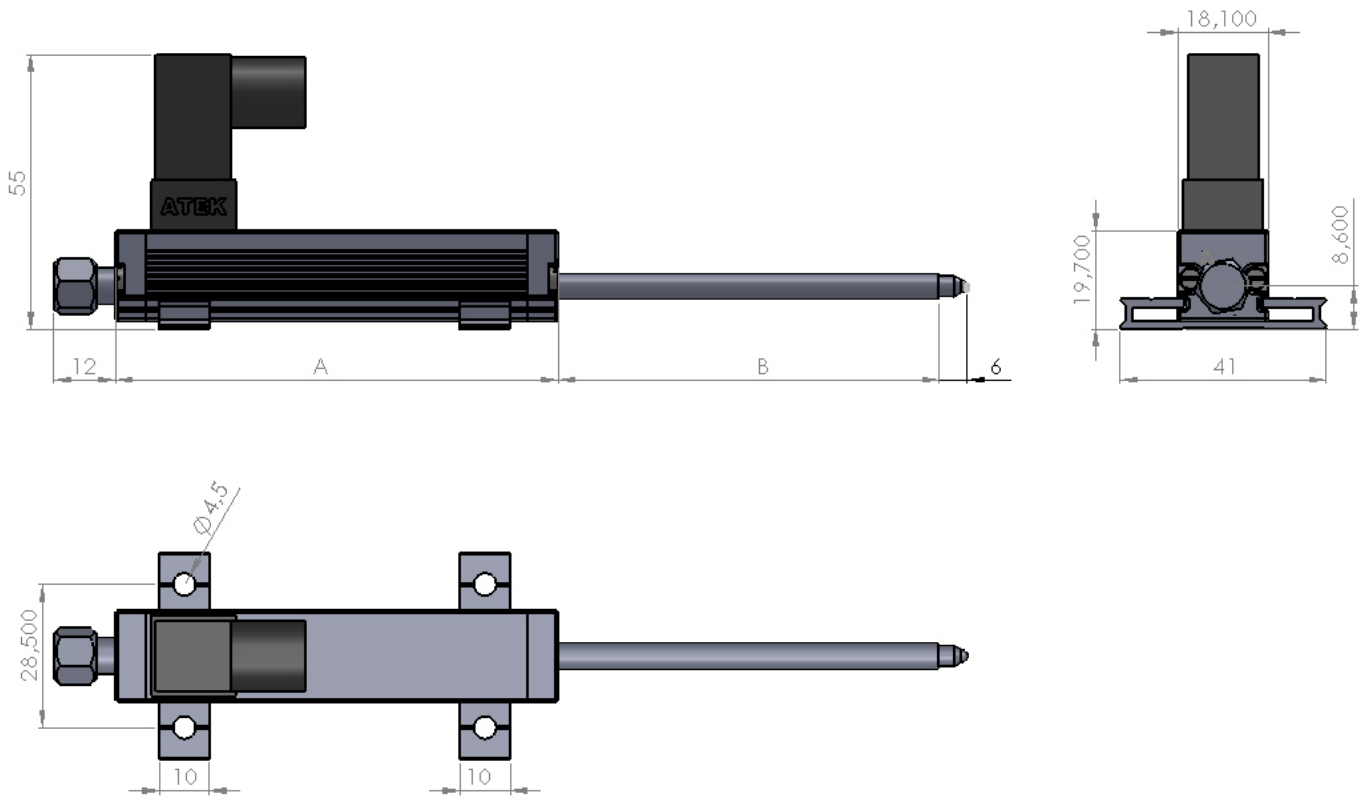

Strokes (mm)	25	50	75	100	150
A	27	52	77	102	152
B	63	88	113	138	188
Electrical Stroke	25	50	75	100	150
Mechanical Stroke	27	52	77	102	152

Order Code

Model No

Defined Stroke Range

Standard Lengths From 10 mm to 150 mm

L F R - 1 0 0



Atek Sensor Technology A.S.

Tuzla KOSB Organize Sanayi Bolgesi Melek Aras Bulvari, No:67 34956 Tuzla - Istanbul / TURKEY

Tel: +90 216 399 44 04

Fax: +90 216 399 44 02

www.ateksensor.com

info@ateksensor.com

