

1700 FLANGE LOAD CELL (U.S. & METRIC)

FEATURES & BENEFITS

- Capacities from 220 to 14K lbf (1 to 63 kN)
- Standard flange design mounts directly to cylinders
- Tension and compression
- Proprietary Interface temp. compensated strain gages
- Performance to 0.05%
- Eccentric load compensated
- 0.0008%/°F (0.0015%/°C) temp. effect on output

STANDARD CONFIGURATION



Model 1720ACK-10KN (Shown)

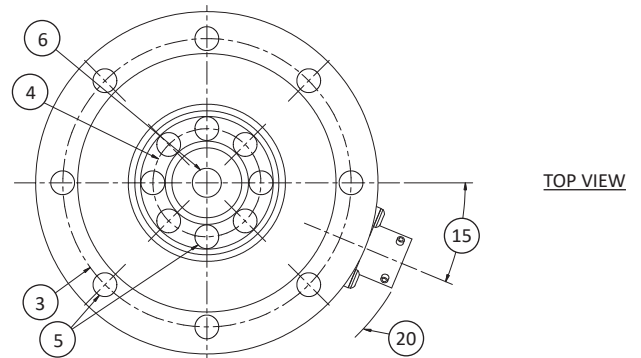
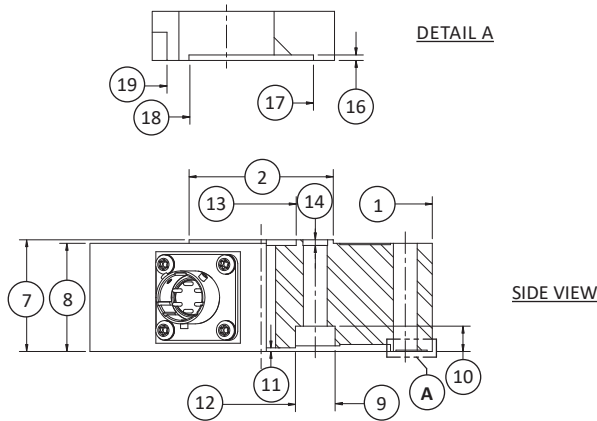

DIMENSIONS

See Drawings	MODEL					
	1710		1720		1730	
	CAPACITY					
	U.S. (lbf)	Metric (kN)	U.S. (lbf)	Metric (kN)	U.S. (lbf)	Metric (kN)
	220, 550, 1.1K, 1.4K	1, 2.5, 5, 6.5	2.2K, 4.5K, 5.5K	10, 20, 25	11K, 14K	50, 63
	in	mm	in	mm	in	mm
(1)	Ø3.03	Ø77.0	Ø3.74	Ø95.0	Ø3.98	Ø101.0
(2)	Ø1.07	Ø27.3	Ø1.57	Ø40.0	Ø1.57	Ø40.0
(3)	Ø2.638	Ø67.0	Ø3.150	Ø80.00	Ø3.39±0.01	Ø86.0±0.01
(4)	Ø0.787	Ø20.0	Ø1.181	Ø30.00	Ø1.18±0.01	Ø30.0±0.01
(5)	Ø0.209	Ø5.30	Ø0.26 THRU	Ø6.6 THRU	Ø0.26 THRU	Ø6.6 THRU
	6 Places EQ SP			8 Places EQ SP		
(6)	M10 X 1 I 0.67 2X □ Ø0.500 + 0.002, -0.000 I 0.08	M10 X 1 I 17 2X □ Ø12.70 +0.05, -0.00 I 2.0	Ø0.315 H9	Ø8.0 H9	Ø0.315 H9	Ø8.0 H9
(7)	1.14	29.0	1.22	31.0	1.22	31.0
(8)	1.06	27.0	1.18	30.0	1.18	30.0
(9)	-	-	Ø1.61	Ø41.0	Ø1.61	Ø41.0
(10)	0.25	6.4	0.28	7.0	0.28	7.0
(11)	-	-	0.04	1.0	0.04	1.0
(12)	-	-	Ø0.75	Ø19.0	Ø0.75	Ø19.0
(13)	-	-	Ø0.76	Ø19.4	Ø0.76	Ø19.4
(14)	R 0.79	R 20.0	0.06 2x	1.6 2x	0.06 2x	1.6 2x
(15)	30°		22.5°		22.5°	
(16)	0.02	0.4	0.02	0.4	0.015	0.38
(17)	Ø2.94	Ø74.6	Ø3.63	Ø92.1	Ø3.91	Ø99.4
(18)	Ø2.40	Ø61	Ø2.95	Ø74.9	Ø2.89	Ø73.3
(19)	Ø2.300, +0.002, -0.000	Ø58.42 +0.5, -0.00	Ø2.83	Ø71.8	Ø2.83	Ø71.8

1700 v2.5 11-17-2023

1700 FLANGE LOAD CELL (U.S. & METRIC)

SPECIFICATIONS

PARAMETERS		MODEL		
		1710	1720	1730
		CAPACITY		
Measuring Range	U.S. (lbf)	220, 550, 1.1K, 1.4K	2.2K, 4.5K, 5.5K	11K, 14K
	Metric (kN)	1, 2.5, 5	10, 20, 25	50, 63
ACCURACY – (MAX ERROR)				
Nonlinearity – %FS		±0.04	±0.04	±0.04
Hysteresis – %FS		±0.03	±0.03	±0.05
Nonrepeatability – %RO		±0.01	±0.01	±0.01
Creep, in 20 min – %		±0.025	±0.025	±0.025
TEMPERATURE				
Compensated Range	°F	+15 to +115	+15 to +115	+15 to +115
	°C	-10 to +45	-10 to +45	-10 to +45
Operating Range	°F	-65 to +200	-65 to +200	-65 to +200
	°C	-55 to +90	-55 to +90	-55 to +90
Effect on Output – % / deg	°F	±0.0008	±0.0008	±0.0008
	°C	±0.0015	±0.0015	±0.0015
Effect on Zero – %RO / deg	°F	±0.0008	±0.0008	±0.0008
	°C	±0.0015	±0.0015	±0.0015
ELECTRICAL				
Rated Output – mV/V (nominal)		2.0	2.0	2.0
Zero Balance – %RO		±1.0	±1.0	±1.0
Bridge Resistance – Ohm (nominal)		350 ± 3.5	350 ± 3.5	350 ± 3.5
Excitation Voltage – VDC MAX		20	20	20
Insulation Resistance – Megohm		5000	5000	5000
MECHANICAL				
Safe Overload – %CAP		±150	±150	±150
Weight	lbs	1.34	3.0	3.0
	kg	0.61	1.36	1.36
Calibration		Tension & Compression		
Material		Aluminum	Alloy steel	

OPTIONS

- Connector protection
- Standardized output
- Transducer Electronic Data Sheet (TEDS)
- Custom calibration
- Multiple bridge
- Dual diaphragm
- Special temperature range
- Cable length
- Add connector to cable

CONNECTOR OPTIONS

- Integral Cable – 10 ft (3 m)
- PT02E-10-6P bayonet connector
- PC04E-10-6P screw-type connector

ACCESSORIES

- Mating connector
- Mating cable
- Instrumentation

1700 FLANGE LOAD CELL (U.S. & METRIC)

BAYONET CONNECTOR



Model 1720ACK-10KN (Shown)

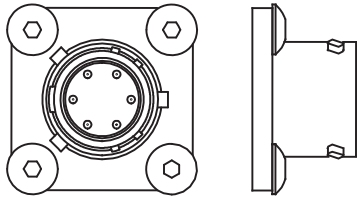

SCREW TYPE CONNECTOR



Model 1720AF-10KN (Shown)

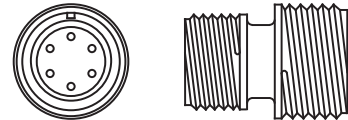

INTEGRAL 10 FT. CABLE CONNECTOR



Model 1720AJ-10KN (Shown)

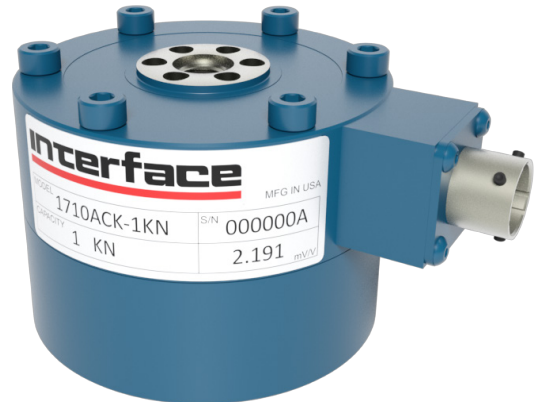
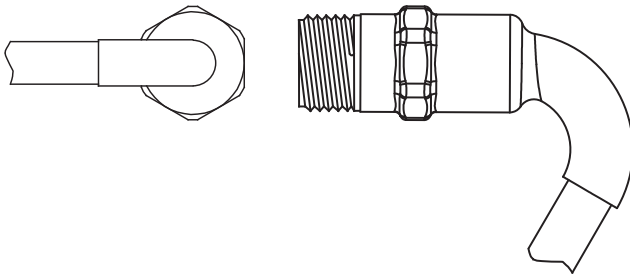

Model 1710ACK-1KN (Shown)