

12x8 FLANGE LOAD CELL (U.S. & METRIC)

FEATURES & BENEFITS

- Standard flange design mounts directly to cylinders
- Tension and compression
- Fatigue rated
- Proprietary Interface temperature compensated strain gages
- Performance to 0.05%
- Eccentric load compensated
- Low deflection
- Alignment hole
- 0.0008%/°F (0.0015%/°C) temp. effect on output
- Barometric compensation
- Ease of installation
- Increased accuracy
- Ability to measure torsion with optional bridges
- Fatigue rated – Can survive 100 million fully reversed load cycles. Ideal for long term cycle testing when failure is unfordable

CONNECTOR OPTIONS

- Integral cable
- PC04E-10-6P screw connector
- PT02E-10-6P bayonet connector

STANDARD CONFIGURATION



Model 1228ACK-30K (Shown)

OPTIONS

- Connector protection
- Standardized output
- Transducer Electronic Data Sheet (TEDS)
- Add connector to cable
- Multiple bridge
- Special threads
- Dual diaphragm
- Special temperature range
- Cable length

ACCESSORIES

- Mating connector
- Instrumentation

Note:

- Dimensions are approximate
- Contact factory for current drawings
- *2.41 (61.2) for 50 kN
- For lower capacities; refer to the 1700 model

All product descriptions are for general information only. They are not to be understood as a guarantee of quality or durability and do not constitute any liability what so ever.

12x8 FLANGE LOAD CELL (U.S. & METRIC)

SPECIFICATIONS

PARAMETERS		MODEL						
		1228	1238	1248	1258	1268	1288	1298
		CAPACITY						
Measuring Range	U.S. (lbf)	11.2K, 22.4K, 30K	55K	110K	220K	330K	539.5K	741.9K
	Metric (kN)	50, 100, 140	250	500	1000	1500	2400	3300
ACCURACY – (MAX ERROR)								
Static Error Band – %FS		±0.05	±0.05	±0.06	±0.10	±0.12	±0.15	±0.20
Nonlinearity – %FS		±0.05	±0.05	±0.06	±0.10	±0.12	±0.15	±0.20
Hysteresis – %FS		±0.05	±0.05	±0.07	±0.10	±0.12	±0.15	±0.20
Nonrepeatability – %RO		±0.01	±0.01	±0.01	±0.01	±0.01	±0.01	±0.01
Creep, in 20 min – %		±0.025	±0.025	±0.025	±0.025	±0.025	±0.025	±0.025
Side Load Sensitivity – %		±0.25	±0.25	±0.25	±0.25	±0.25	±0.25	±0.25
Eccentric Load Sensitivity – %	in	±0.25	±0.25	±0.25	±0.25	±0.25	±0.25	±0.50
	mm	±0.01	±0.01	±0.01	±0.01	±0.01	±0.01	±0.02
TEMPERATURE								
Compensated Range	°F	+15 to +115	+15 to +115	+15 to +115	+15 to +115	+15 to +115	+15 to +115	+15 to +115
	°C	-10 to +45	-10 to +45	-10 to +45	-10 to +45	-10 to +45	-10 to +45	-10 to +45
Operating Range	°F	-65 to +200	-65 to +200	-65 to +200	-65 to +200	-65 to +200	-65 to +200	-65 to +200
	°C	-55 to +90	-55 to +90	-55 to +90	-55 to +90	-55 to +90	-55 to +90	-55 to +90
Effect on Zero – %RO / deg	°F	±0.0008	±0.0008	±0.0008	±0.0008	±0.0008	±0.0008	±0.0008
	°C	±0.0015	±0.0015	±0.0015	±0.0015	±0.0015	±0.0015	±0.0015
Effect on Output – % / deg	°F	±0.0008	±0.0008	±0.0008	±0.0008	±0.0008	±0.0008	±0.0008
	°C	±0.0015	±0.0015	±0.0015	±0.0015	±0.0015	±0.0015	±0.0015
ELECTRICAL								
Rated Output – mV/V (Nominal)		2.2	2.2	2.2	2.2	2.2	2.2	2.2
Excitation Voltage – VDC MAX		20	20	20	20	20	20	20
Bridge Resistance – Ohm (Nominal)		350 ±3.5	350 ±3.5	350 ±3.5	350 ±3.5	350 ±3.5	350 ±3.5	350 ±3.5
Zero Balance – %RO MAX		±1.0	±1.0	±1.0	±1.0	±1.0	±1.0	±1.0
Insulation Resistance – Megohm – MIN		5000	5000	5000	5000	5000	5000	5000
MECHANICAL								
Safe Overload – %CAP		±275	±275	±275	±275	±275	±275	±275
Deflection @ RO	in	0.001	0.002	0.004	0.005	0.006	Consult factory	
	mm	0.03	0.05	0.10	0.13	0.15	Consult factory	
Natural Frequency – kHz		7	5.9	4.4	5	5.1	5.5	5.5
Weight	lbs	9.32	23.16	65.42	102.00	203.79	442.00	901.48
	kg	4.28	10.51	29.67	46.27	92.44	200.49	408.90
Calibration		Tension & Compression						
Material		Alloy steel						

12x8 FLANGE LOAD CELL (U.S. & METRIC)

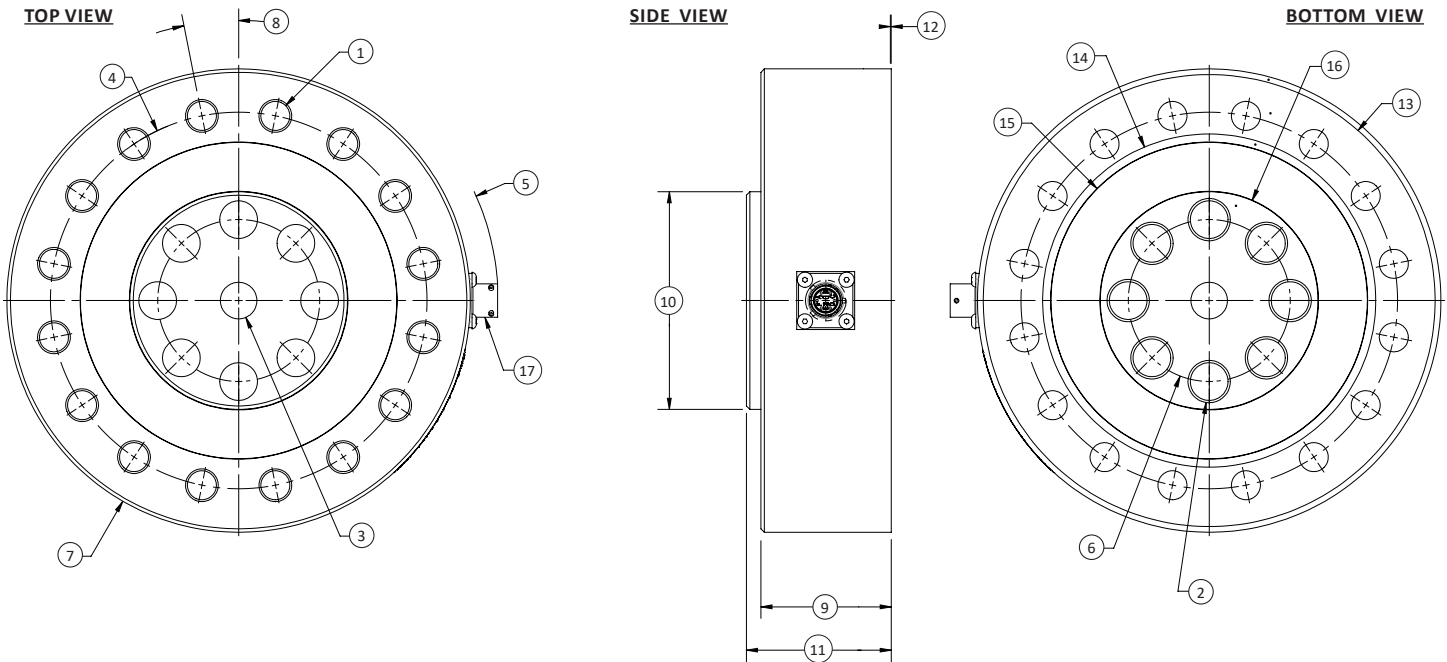

DIMENSIONS (1228, 1238, & 1248)

See Drawing	MODEL					
	1228		1238		1248	
	CAPACITY					
	U.S. (lbf)	Metric (kN)	U.S. (lbf)	Metric (kN)	U.S. (lbf)	Metric (kN)
	11.2K, 22.4K, 30K	50, 100, 140	55K	250	110K	500
	in	mm	in	mm	in	mm
(1)	12 x Ø0.406 THRU ∇ 0.44 x (90°/60°)	12 x Ø10.3 THRU ∇ Ø11.2 (90°/60°)	16 x Ø0.50 THRU	16 x Ø12.7 THRU	16 x Ø0.66 THRU ∇ 0.69 x 90°	16 x Ø16.7 THRU ∇ 17.5 x 90°
(2)	8 x Ø0.41 THRU ∇ 0.46 x 90°	8 x Ø10.5 THRU ∇ 11.7 x 90°	8 x Ø0.65 THRU ∇ Ø0.73 x 90°	8 x Ø16.5 THRU ∇ Ø18.5 x 90°	8 x Ø0.65 THRU	8 x Ø16.51 THRU
(3)	Ø0.31 THRU └┘ Ø0.3166/0.3155 ↓ 0.39 BOTH ENDS	Ø7.9 THRU └┘ Ø0.8042/8.014 ↓ 10.0 BOTH ENDS	Ø0.6306/0.6299 THRU	Ø16.017/15.999 THRU	Ø0.6306/0.6299 THRU	Ø16.017/15.999 THRU
(4)	Ø5.125	Ø130.2	Ø6.500	Ø165.1	Ø9.000	Ø228.60
(5)	R3.66 MIN	R93.0 MIN	R4.46 MIN	R113.3	R6.57	R166.9
(6)	Ø1.772	Ø45.0	Ø2.795	Ø71.0	Ø2.798	Ø70.99
(7)	Ø6.06	Ø153.9	Ø8.00	Ø203.1	Ø11.00	Ø279.3
(8)	15°		11.25°		11.25°	
(9)	1.63	41.3	2.25	57.2	3.00	76.2
(10)	Ø2.41	Ø61.2	Ø3.76	Ø95.4	Ø4.81	Ø122.2
(11)	1.75	44.5	2.50	63.5	3.50	88.9
(12)	0.02	0.4	0.02	0.5	0.3	0.8
(13)	Ø5.86	Ø148.8	Ø7.80	Ø198.1	Ø10.60	Ø269.2
(14)	Ø4.3	Ø109.2	Ø5.75	Ø146.1	Ø7.40	Ø188.0
(15)	Ø4.01	Ø101.9	Ø5.47	Ø139.0	Ø6.78	Ø172.1
(16)	Ø2.41	Ø61.2	Ø3.76	Ø95.4	Ø4.81	Ø122.2
(17)	PC04E-10-6P		PT02E-10-6P		PT02E-10-6P	

International System of Units (SI) dimensions and capacities are provided for conversion only. Standard products have U.S. capacities and dimensions. SI capacities available upon special request and at an additional cost.

12x8 FLANGE LOAD CELL (U.S. & METRIC)

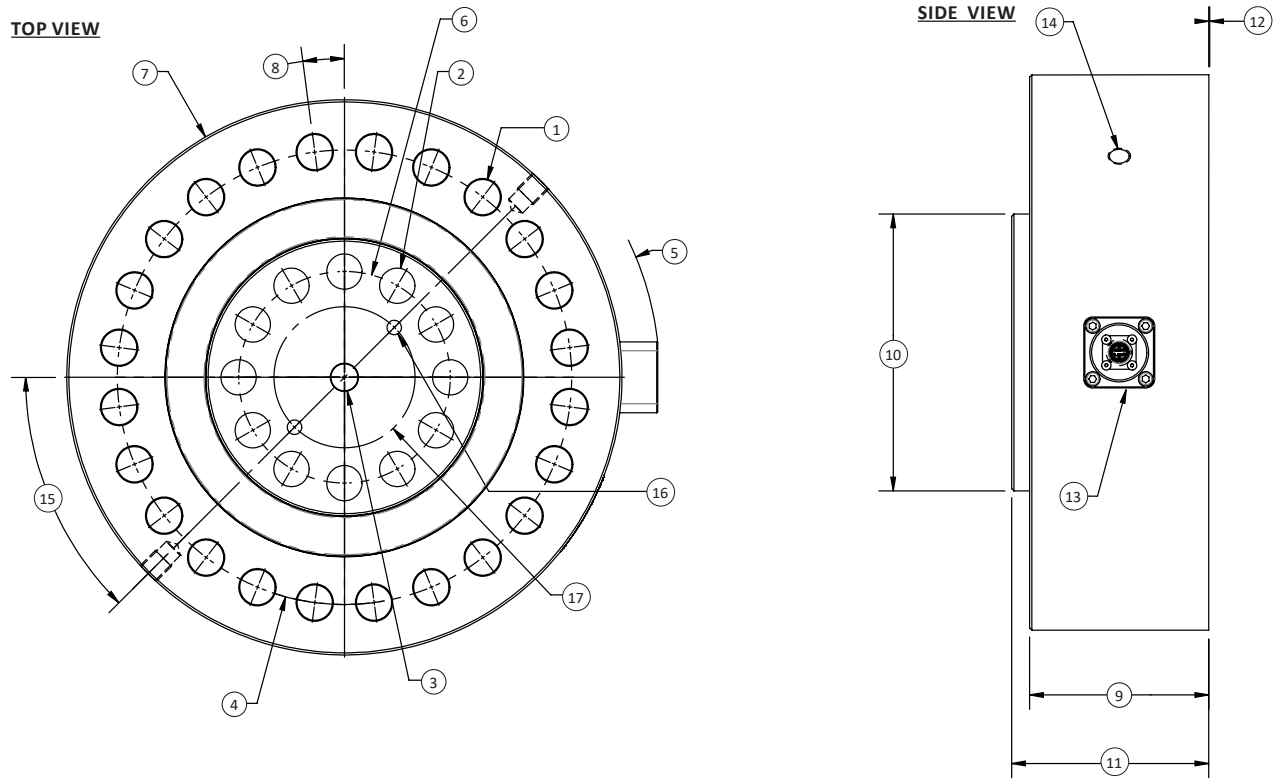

DIMENSIONS (1268)

See Drawing	MODEL	
	1268	
	CAPACITY	
	U.S. (lbf)	Metric (kN)
	330K	1500
	in	mm
(1)	0.98	25.0
(2)	12 x Ø0.984 THRU	12 x Ø24.99 THRU
(3)	Ø0.75 THRU □ Ø(0.7882/0.7874) ↓ 0.79 BOTH ENDS	Ø19.05 THRU □ Ø(20.02/20.00) ↓ 20.1 BOTH ENDS
(4)	Ø12.684	Ø322.17
(5)	R8.80 MIN	R223.6 MIN
(6)	Ø5.906	Ø150.01
(7)	Ø15.50	Ø393.7
(8)	7.5°	
(9)	5.00	127.0
(10)	Ø7.73	Ø196.3
(11)	5.50	139.7
(12)	0.03	0.8
(13)	PT02E-10-6P(023)	
(14)	2 x M16x2-6H ↓ 0.60 Lifting Threads	2 x M16x2-6H ↓ 15.2 Lifting Threads
(15)	45°	
(16)	2 x M12x1.75-6H ↓ 0.70	2 x M12x1.75-6H ↓ 17.8
(17)	Ø3.937	Ø100.00

International System of Units (SI) dimensions and capacities are provided for conversion only. Standard products have U.S. capacities and dimensions. SI capacities available upon special request and at an additional cost.

12x8 FLANGE LOAD CELL (U.S. & METRIC)

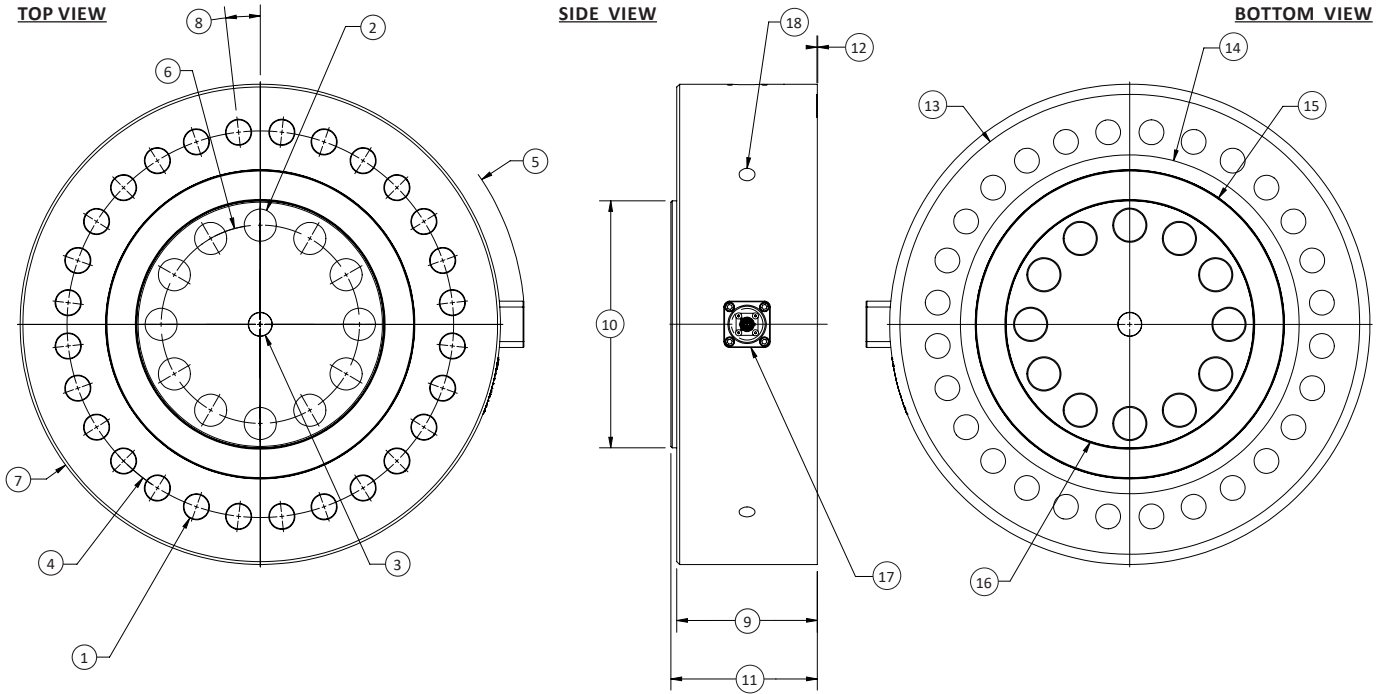

DIMENSIONS (1258 & 1288)

See Drawing	MODEL			
	1258		1288	
	CAPACITY			
	U.S. (lbf)	Metric (kN)	U.S. (lbf)	Metric (kN)
in	mm	in	mm	
(1)	20 x Ø0.83 THRU √ 0.89 x 90°	20 x Ø21 THRU √ 22 x 90°	28 x Ø1.06 THRU	28 x Ø26.9 THRU
(2)	8 x Ø0.969 THRU	8 x Ø24.61 THRU	18 x Ø1.37 THRU √ 1.46±0.02 x 90° FAR SIDE	18 x Ø34.8 THRU √ 37.1±0.4 x 90° FAR SIDE
(3)	Ø0.59 THRU □ Ø(0.6299/0.6306) ↓ 0.79 BOTH ENDS	Ø15.0 THRU □ Ø(15.999/16.017) ↓ 20.0 BOTH ENDS	Ø1.00 THRU □ Ø(1.0236/1.0244) ↓ 1.05 BOTH ENDS	Ø31.8 THRU □ Ø(26.000/26.020) ↓ 26.7 BOTH ENDS
(4)	Ø9.500	Ø241.30	Ø16.500	Ø419.10
(5)	R7.07	R179.5	R11.29 MIN	R286.8 MIN
(6)	Ø4.134	Ø105.00	Ø8.465	Ø215.00
(7)	Ø12.00	Ø304.8	Ø20.50	Ø520.7
(8)	9°		6.43°	
(9)	4.25	108.0	6.00	152.4
(10)	Ø5.68	Ø144.3	Ø10.55	Ø267.9
(11)	4.50	114.3	6.25	158.8
(12)	0.03	0.8	0.03	0.8
(13)	Ø11.40	Ø289.6	Ø19.63	Ø498.6
(14)	Ø8.51	Ø216.2	Ø14.46	Ø367.3
(15)	Ø7.60	Ø193.0	Ø13.20	Ø335.2
(16)	Ø5.68	Ø144.3	Ø10.55	Ø267.9
(17)	PT02E-10-6P		PT02E-10-6P	
(18)	2 x M16x2-6H ↓ 0.60	2 x M16x2-6H ↓ 15.2	4 x M20x2.5-6G ↓ 1.00	4 x M20x2.5-6G ↓ 25.4

International System of Units (SI) dimensions and capacities are provided for conversion only. Standard products have U.S. capacities and dimensions. SI capacities available upon special request and at an additional cost.

12x8 FLANGE LOAD CELL (U.S. & METRIC)

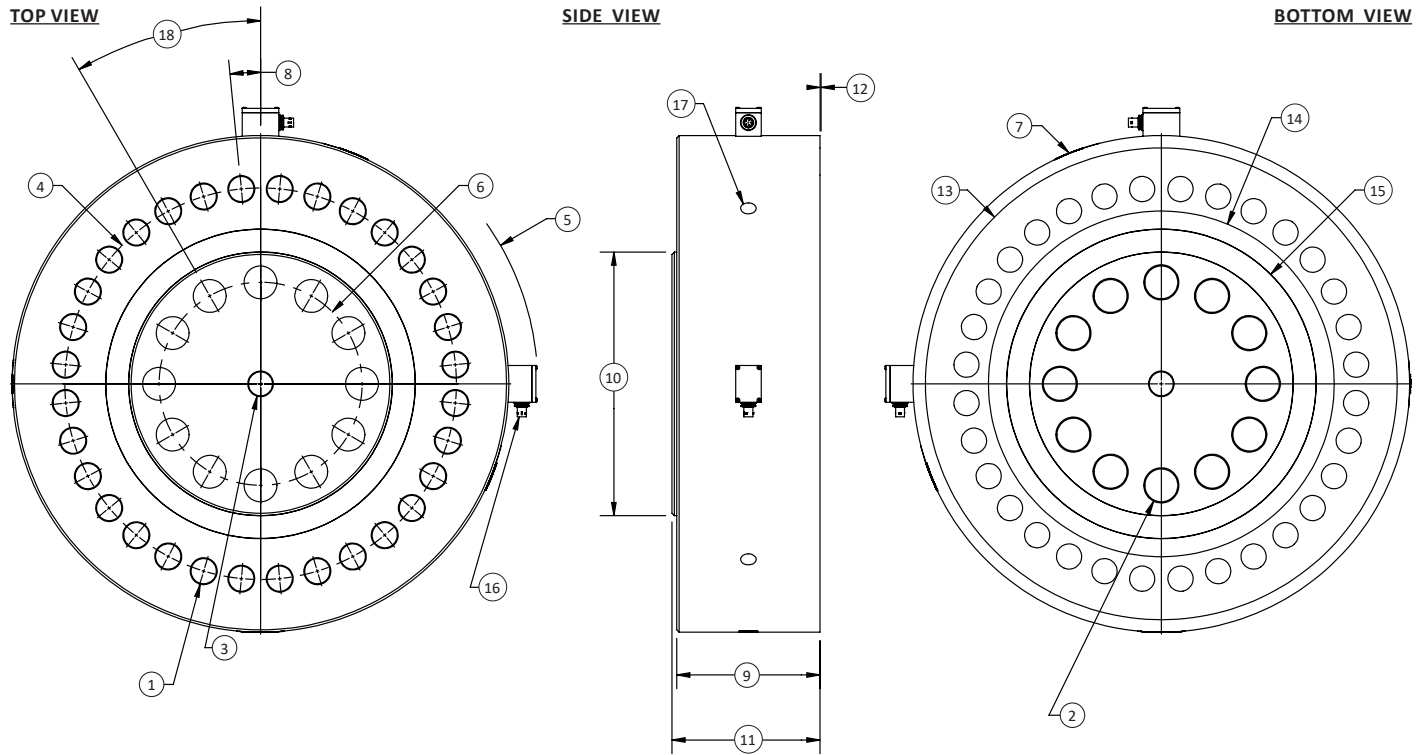

DIMENSIONS (1298)

See Drawing	1298	
	U.S. (lbf)	Metric (kN)
	741.9K	3300
	in	mm
(1)	32 x \varnothing 1.32 THRU ALL	32 x \varnothing 33.53 THRU ALL
(2)	12 X 1.72 THRU ALL \varnothing 1.84 \pm 0.02 X 90° NEAR SIDE	12 X 43.7 THRU ALL \varnothing 46.74 \pm 0.51 X 90° NEAR SIDE
(3)	\varnothing 1.25 THRU ALL \square \varnothing 1.3391 \pm 0.0005 \downarrow 1.33, BOTH ENDS	\varnothing 31.8 THRU ALL \square \varnothing 34.013 \pm 0.013 \downarrow 33.8, BOTH ENDS
(4)	\varnothing 20.500	\varnothing 520.70
(5)	R14.05 MIN	R356.9 MIN
(6)	\varnothing 10.63	\varnothing 270.0
(7)	\varnothing 26.00	\varnothing 660.4
(8)	5.63°	
(9)	7.50	190.5
(10)	\varnothing 13.79	350.27
(11)	7.75	196.85
(12)	0.03	0.76
(13)	\varnothing 24.70	\varnothing 627.38
(14)	\varnothing 18.10	\varnothing 459.74
(15)	\varnothing 16.21	\varnothing 411.73
(16)	PT02E-10-6P	
(17)	4 x M24 x 3 \downarrow 1.40	4 x M24 x 3 \downarrow 35.6
(18)	30°	

International System of Units (SI) dimensions and capacities are provided for conversion only. Standard products have U.S. capacities and dimensions. SI capacities available upon special request and at an additional cost.