



VS102 Electronic Vibration Switch

Introduction

The VS102 Electronic Vibration Switch is designed to be the cost effective solution for vibration switch applications. The VS102's unique and rugged design is suitable for harsh environments and hazardous areas. It has a universal mounting feature, relays or triacs, and a 4-20mA output.

Applications

- ✓ **Pumps**
- ✓ **Motors**
- Industrial Fans**
- ✓ **Heat Exchangers/ Cooling Towers**
- ✓ **Engines**
- ✓ **Reciprocating Compressors**
- ✓ **Centrifuges**
- ✓ **Rock or Coal Crushers**

Features

- ✓ **Direct replacement for mechanical switches with universal mounting plates and studs**
- ✓ **4-20mA output**
- ✓ **Dual alarms with relays or triacs**
- ✓ **NEMA 4X, IP65 environmental rating**
- ✓ **Hazardous area approvals: CSA, CE, PCEC**

Specifications

Frequency Range: 2 to 1000 Hz

Alarms: Dual alarms

Dry-contact relay: 5A 230VAC/115VAC or 5A 30VDC

Triac: 5A 230VAC. Optically Isolated, Standard NC

Temperature Limit: -40°C to +85°C (-40°F to +185°F)

Power Supply:

95 - 250VAC @ 100mA, 50-60Hz, or

22 - 30VDC @ 200mA

Enclosure: Cast Aluminum (copper free)

Coating: Standard plastic coating for all cased aluminum parts outside. Mounting plate, mounting stud and local reset are 304 stainless steel.

Environmental Rating: NEMA 4X, IP65

Hazard Rating: See order information



Physical

Temperature:

Operation: -40°C to +85°C (-40°F to +185°F)

Storage: -50°C to +120°C (-58°F to +248°F)

Dimensions:

See attached drawing

Weight:

1.4kg (3 lbs)



Order Information

VS102-ABCD-EFGG

A: Alarms***

- A = 0: Dual SPDT Relays
- A = 1*: Single SPDT Relay
- A = 2: Single SPST Triac, NO
- A = 3: Dual SPST Triacs, NO
- A = 4: Single SPST Triac, NC
- A = 5: Dual SPST Triacs, NC

B: Conduit Entries

- B = 0*: 3/4" NPT
- B = 1: M20x1.5

C: Mounting Plate or Mounting Stud

- C = 0*: Mounting Plate PT500-13
- C = 1: Mounting Plate PT500-14
- C = 2: Mounting Stud 3/4" NPT
- C = 3: Mounting Stud M20x1.5

D: Power Supply

- D = 0*: 115VAC or 230VAC
- D = 1: 24VDC

E: Hazardous Area Approvals

- E = 0: CE Mark (With Local Reset)
- E = 1: Multiple approvals (With Local Reset):
 - CSA: Class I, Div 1, Groups B, C, D, T4 & T6
 - T4@Ta= -40°C to +100°C
 - T6@Ta= -40°C to +70°C
 - CERTIFICATE: 2079756
 - PCEC: ExdIICT4
 - CE Mark
- E = 2: Multiple approvals (No Local Reset):
 - CSA: Class I, Div 1, Groups A, B, C, D, T4 & T6
 - T4@Ta= -40°C to +100°C
 - T6@Ta= -40°C to +70°C

CERTIFICATE: 2079756

PCEC: ExdIICT4

CE Mark

E = 3*: CE Mark (No Local Reset)

F: 4-20mA Outputs

- F = 0: None
- F = 1*: 4-20mA

GG: Full Scale

- GG = 09: 0 - 5.0g pk
- GG = 10: 0 - 10.0g pk
- GG = 11: 0 - 20.0g pk
- GG = 20: 0 - 12.5 mm/s pk
- GG = 21: 0 - 20mm/s pk
- GG = 22: 0 - 25mm/s pk
- GG = 23: 0 - 50mm/s pk
- GG = 24: 0 - 100mm/s pk
- GG = 30: 0 - 12.5 mm/s rms
- GG = 31: 0 - 20mm/s rms
- GG = 32*: 0 - 25mm/s rms
- GG = 33: 0 - 50mm/s rms
- GG = 34: 0 - 100mm/s rms
- GG = 40: 0 - 0.5ips pk
- GG = 41: 0 - 1.0ips pk
- GG = 42: 0 - 2.0ips pk
- GG = 43: 0 - 4.0ips pk
- GG = 50: 0 - 0.5ips rms
- GG = 51: 0 - 1.0ips rms
- GG = 52: 0 - 2.0ips rms
- GG = 53: 0 - 4.0ips rms

Note:

* Factory default

*** The default setting is alarm non-latching. Alarm delays 6s and relay works in non-energized mode.



Accessories



3/4" NPT seal
PT500-18

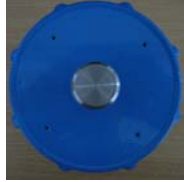

Cover1*
PT500-2



Cover2 **
PT500-3



magnetic ring***
PT580-10

Note:

* Cover1: Relates to the E option; if D=0 or 1, the factory default option is Cover1.

** Cover2: Relates to the E option; if D=2 or 3, the factory default option is Cover2.

*** Magnetic ring: One at the factory default setting. When in extremely environment or both ends of the vibration switch have wires, user should order additional accessories to acquire good effects. Please refer to figure Trouble Shooting 6 for installation method.



VS102 Mechanical Outline Drawing

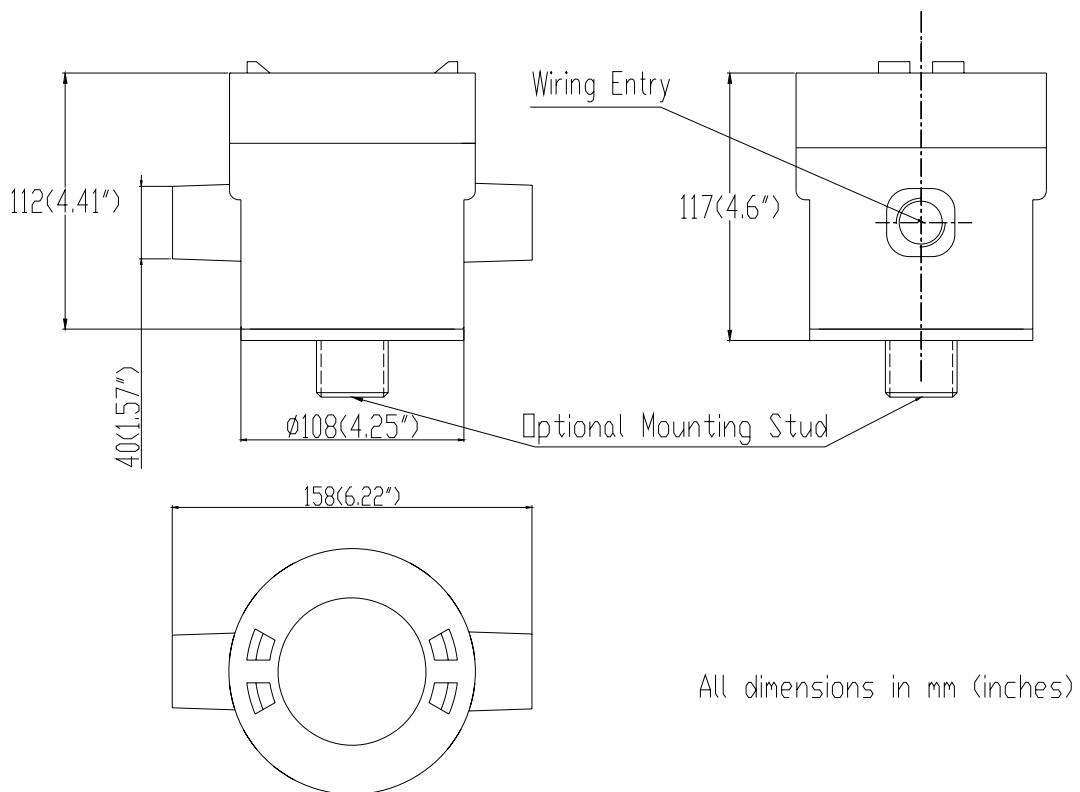
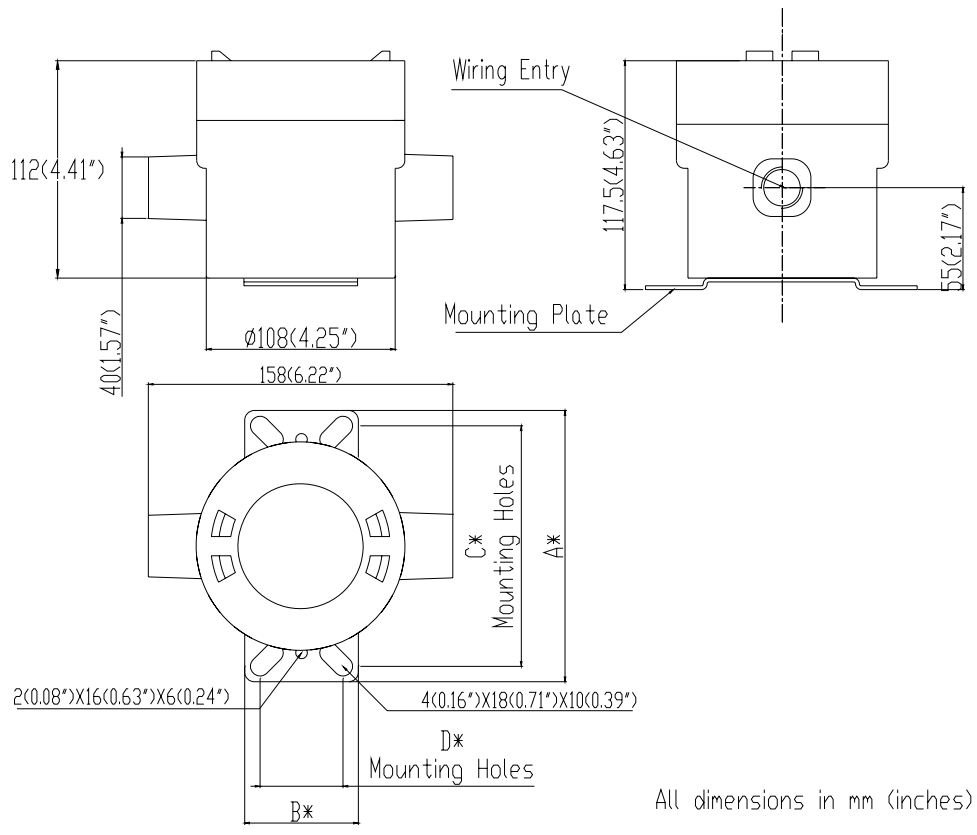

Note: The default case has no local Reset.



Mounting Plate, Mounting Studs

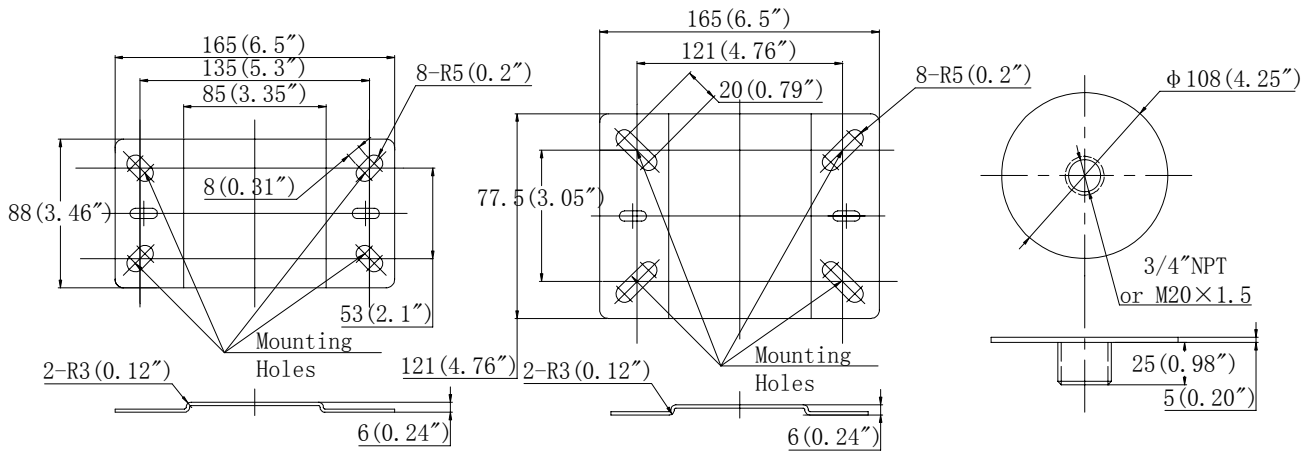

All dimensions in mm (inches)

PT500-13

PT500-14

PT500-15 (3/4" NPT)

PT500-17 (M20 x 1.5)



Field-Wiring Diagram

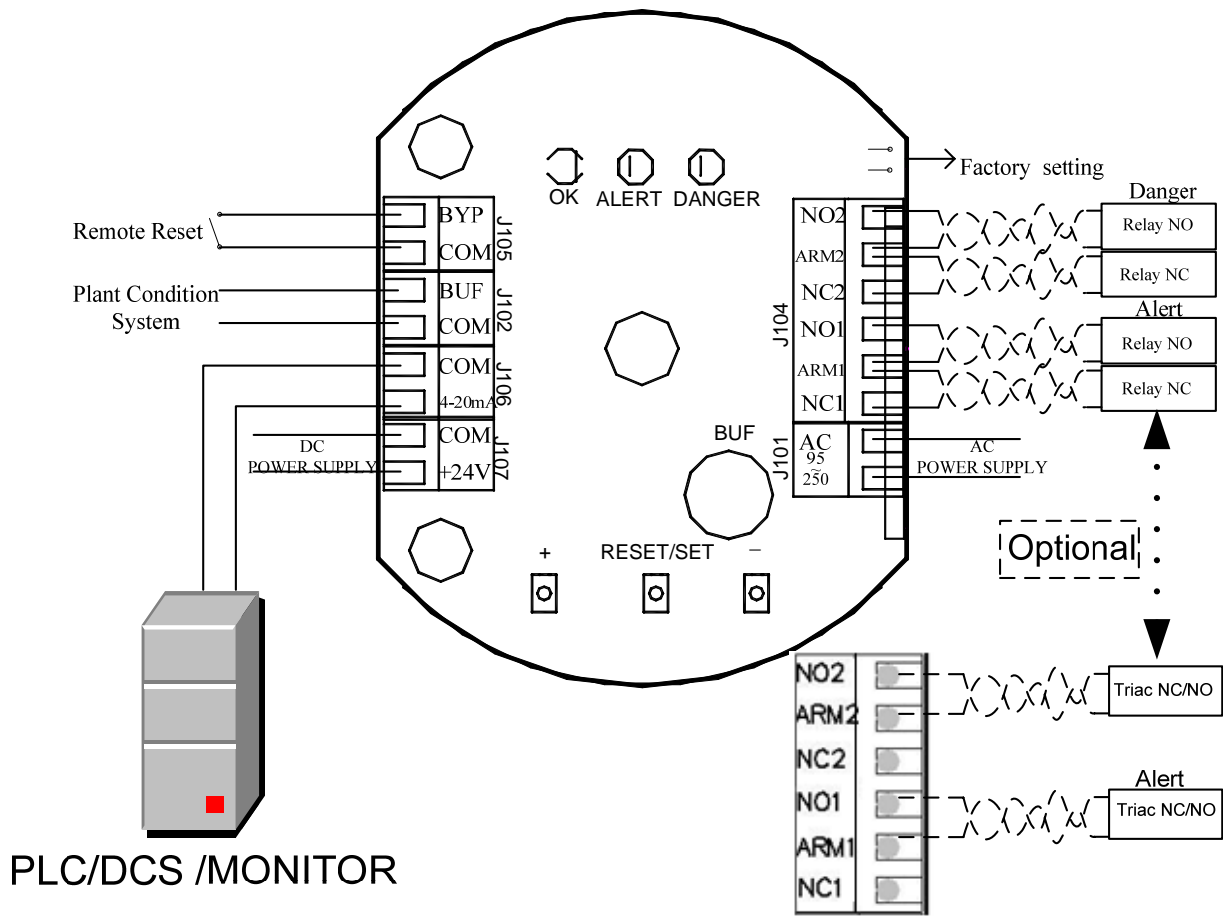

Note: 1. Select Relay/Triac NO/Triac NC as per Alarm option
2. If single alarm is selected, Alert is valid only