

Model RT10E High Capacity Rotary Transformer Torque Transducer

Why the Interface model RT10E High Capacity Rotary Transformer Torque Transducer is the best in class:

- 4X overload rating
- Infinite fatigue life
- Hardened to EMI from adjustable speed drives
- Performance to 0.07%
- Bidirectional operation including stall
- Ferrite-free rotary transformer coupling
- Calibration & balance free of cable effects
- Unexcelled immunity to machinery magnetic fields
- 15-5 PH stainless shaft, splash proof & corrosion resistant
- mV/V output compatible with carrier amplifiers

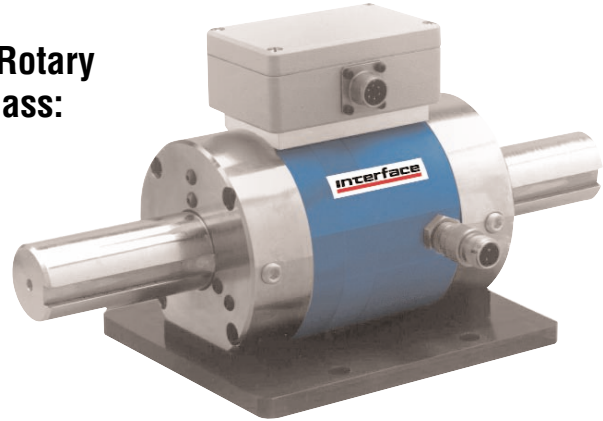

OPTIONS*

- On-board Signal Conditioning**
- Digital Output-RS232**
- Enhanced Performance
- Foot Mount (shown in photo)
- Standard & Zero Velocity Speed Pickups
- Flange Style Mount

ACCESSORIES*

- Interconnect Cables
- Digital Readout (9850)

*Please call for additional information
 **Please consult factory for specifications

DIMENSIONS (inch)

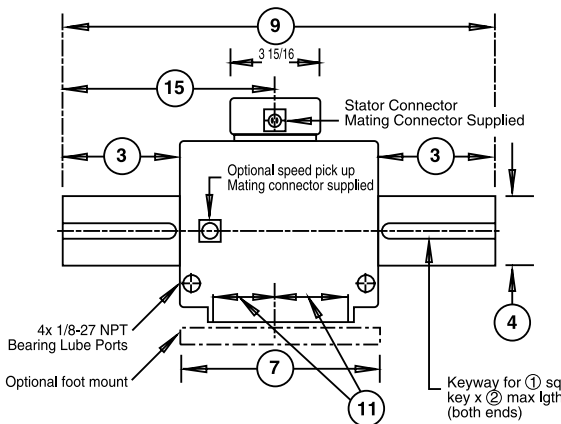
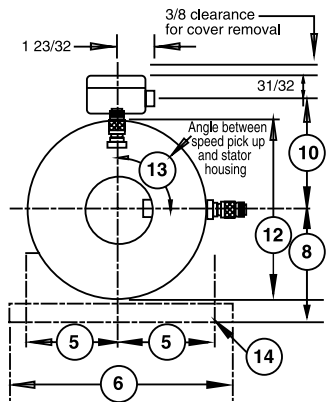

See Drawing	CAPACITY (lb-in)								
	25 to 100	250 to 500	500 to 1K	2K to 5K	10K to 20K	25K to 50K	100K to 250K	500K to 1M	1.5M to 2M
①	0.187	0.187	0.250	0.375	0.625	0.750	1.000	Note 3	Note 4
②	1.125	1.625	1.750	2.750	3.500	4.500	6.500	8.000	12
③	1.50	2.00	2.00	3.38	4.13	5.13	7.56	9.00	13.50
④	0.625	0.750	1.000	1.500	2.500	3.000	4.500	7.750	9.375
⑤	2.25	2.25	2.625	2.625	4.25	4.25	4.25	7.00	8.50
⑥	5.50	5.50	6.25	6.25	10.00	10.00	10.00	15.50	18.50
⑦	5.50	5.50	7.00	7.00	8.75	8.75	7.75	18.00	20.00
⑧	2.250	2.250	2.500	2.500	5.000	5.000	5.000	8.000	9.750
⑨	8.50	9.50	10.00	12.75	17.00	19.00	23.00	36.00	47.00
⑩	4.219	4.219	2.969	2.969	4.875	4.875	5.125	7.875	9.500
⑪	1.500	1.500	1.500	1.500	2.813	2.813	2.813	7.875	8.875
⑫	3.469	3.469	2.563	2.563	7.938	7.938	8.500	13.875	17
⑬	90°	90°	90°	90°	0°	0°	0°	0°	0°
⑭	.254	.304	.406	.609	Note 2	Note 2	Note 2	Note 2	Note 2
⑮	4.250	4.750	5	6.375	9.500	9.500	12.844	18	23.500

1. Tolerance on ④ diameter is +0.0000/-0.0005 for diameters ≤ 2.500 inch and +0.000/-0.001 for diameter ≥ 2.500 inch.
2. Slotted 0.531 inch wide by 1.125 inch long.
3. Dual rectangular keyways at each end are 2.000 inch wide by 1.500 inch high.
4. Dual rectangular keyways at each end are 2.500 inch wide by 1.750 inch high.

SPECIFICATIONS

PARAMETERS	MODEL	
	STANDARD	ENHANCED
ACCURACY – (MAX ERROR)		
Combined Error–%FS	±0.1	±0.07
Nonlinearity–%FS	±0.1	±0.05
Hysteresis–%FS	±0.1	±0.05
Nonrepeatability–%FS	±0.05	±0.02
Stability, 6 Months–%FS	±0.15	±0.10
Rotational Effect on Zero–%FS	±0.05	±0.02
TEMPERATURE		
Effect on Zero–%FS/°F	±0.002	±0.001
Span–%/°F	±0.002	±0.001
Compensated Range–°F	+75 to +175	
Usable Range–°F	-25 to +185	
Storage Range–°F	-65 to +225	
ELECTRICAL		
Fully bi-directional, dual output with common characteristics, as follows		
Clockwise (CW) Torque	+1.5 mV/V	
Counterclockwise (CCW) Torque	-1.5 mV/V	
Zero Balance	±1% of FS, nominal	
Excitation (MAX)	3-6 V rms, 3 khz ±10% sine wave only	
Readout	Strain gage carrier amplifier	

*Specifications apply to mV/V models only. When selecting the **ON-BOARD SIGNAL CONDITIONING** or **DIGITAL OUTPUT** options please contact factory for specification details.

TORQUE RANGE		SPEED RATING	SHAFT* STIFFNESS	ROTATING INERTIA	MAX. WT.
[lb-in]	[Nm]	[rpm]	[lb-in/radian]	[oz-in sec ²]	[lbs]
25	2.82	0 to ±15,000	5,590	0.035	11
50	5.65	0 to ±15,000	11,700	0.035	11
100	11.3	0 to ±15,000	21,400	0.035	11
250	28.2	0 to ±15,000	50,200	0.036	12
500	56.5	0 to ±15,000	56,000	0.036	12
500	56.5	0 to ±10,000	154,000	0.11	23
1K	113	0 to ±10,000	214,000	0.11	23
2K	226	0 to ±10,000	421,000	0.16	26
5K	565	0 to ±10,000	593,000	0.16	26
10K	1,130	0 to ±8,000	1,800,000	2.3	105
20K	2,260	0 to ±8,000	2,700,000	2.4	105
25K	2,820	0 to ±6,000	5,700,000	2.8	115
50K	5,650	0 to ±6,000	7,100,000	3.0	115
100K	11,300	0 to ±3,600	29,000,000	11.0	150
250K	28,200	0 to ±3,600	36,000,000	11.7	150
500K	56,500	0 to ±1,800	125,000,000	207	780
1M	113,000	0 to ±1,800	142,000,000	218	800
1.5M	170,000	0 to ±1,200	221,000,000	567	1455
2M	226,000	0 to ±1,200	227,000,000	582	1475

*Stiffness is conservatively rated and includes both the torsion section and shaft ends.