

# Model MRT Miniature Reaction Torque Transducer

- Low capacity – 0.2 to 20 Nm
- Proprietary Interface temperature compensated strain gages
- Small size – 41 x 33 mm (1.6 in OD x 1.25 in)
- Excellent linearity & repeatability
- Low deflection - high torsional stiffness



## DIMENSIONS

See Drawing	CAPACITY (Nm)
	inch (mm)
(1)	M5 x 0.8 – 6H x 0.20 Deep
(2)	.119 ±0.001 (3.02 ±0.03)
(3)	.237 thru (6.02)
(4)	.984 (24.99)
(5)	1.375 (34.95)
(6)	1.25 (31.8)
(7)	1.60 (40.6)
(8)	1.50 (38.1)
(9)	M5 x 0.8 – 6H x 0.20 Deep

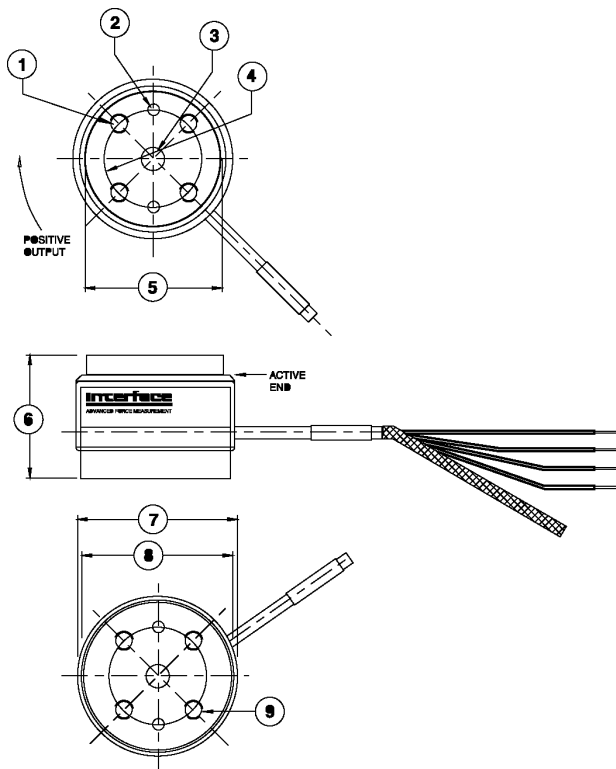

## SPECIFICATIONS

Standard Capacities (Nm)	0.2, 2, 20
Equivalent (in-lb)	1.77, 17.7, 177
<b>ACCURACY – (MAX ERROR)</b>	
Nonlinearity-% FS	±0.10
Hysteresis-% FS	±0.10
Nonrepeatability-% RO	±0.05
Creep, in 20 min-%	±0.10
<b>TEMPERATURE</b>	
Compensated Range-°F	15 to 115
Compensated Range-°C	-10 to 45
Operating Range-°F	-65 to 200
Operating Range-°C	-55 to 90
Effect on Zero-% RO/100F°	±0.20
Effect on Output-%/100F°	±0.10
<b>ELECTRICAL</b>	
Rated Output-mV/V (Nominal)	2.00 ±0.30
Zero Balance-% RO	±1.0
Input Resistance-Ohms	700 + 100/-7
Output Resistance-Ohms	700 ±7
Insulation Resistance-Megohm	>5000
Excitation, Nominal	10 VDC
Excitation, Maximum	20 VDC
<b>MECHANICAL</b>	
Overload:	
-safe torsion-% CAP	±150
-ultimate torsion-% CAP	±400
-safe side load-N	13, 110, 400
-lbf	3, 25, 90
-safe overhung moment-% CAP	100
- safe mounting torque-Nm	0.3, 3, 9
-in-lb	2.7, 27, 80
Deflection at capacity-radian	0.007, 0.003, 0.003
Cable length-feet	5