

PROPRIETARY AND CONFIDENTIAL

THE INFORMATION CONTAINED IN THIS DRAWING IS THE SOLE PROPERTY OF DYTRAN INSTRUMENTS INC. ANY REPRODUCTION IN PART OR AS A WHOLE WITHOUT THE WRITTEN PERMISSION OF DYTRAN INSTRUMENTS, INC. IS PROHIBITED

REVISIONS

REV	ECN	DESCRIPTION	BY/DATE	CHK	APPR
A	6816	INITIAL RELEASE	RT 06/04/10	<i>DV</i>	<i>ANJ</i>

MODEL	SENSITIVITY
3221C	10 pC/G ±15%
3221C2	5 pC/G ±15%

ANODIZED ALUMINUM WASHERS
SHRINK TUBING
MOUNTING ASSEMBLY 6297 MODEL (SUPPLIED)

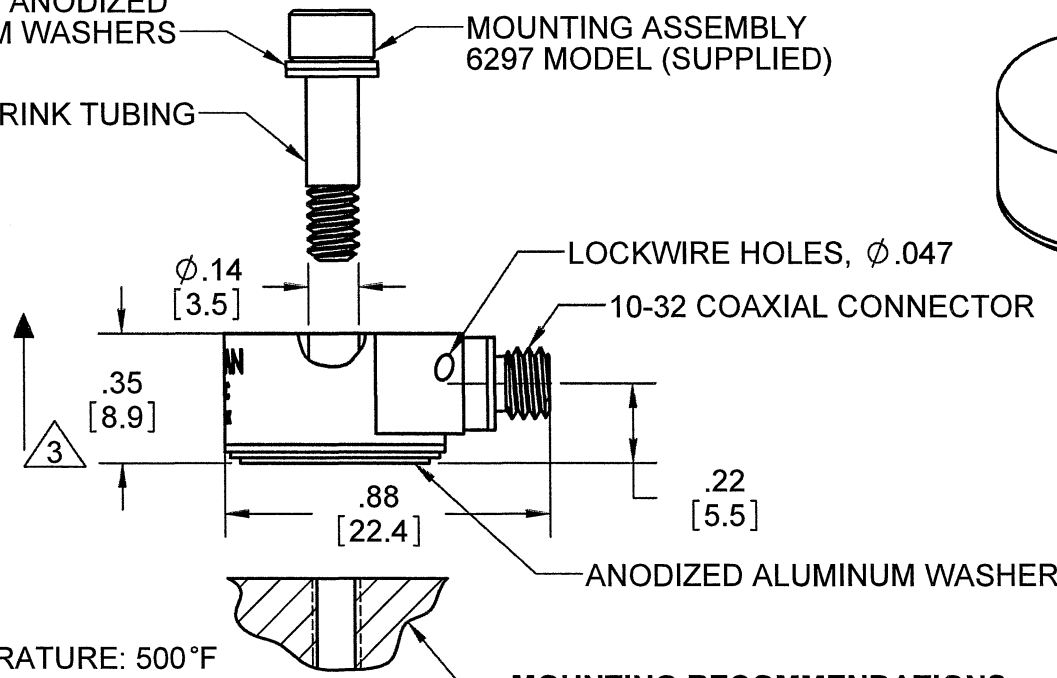
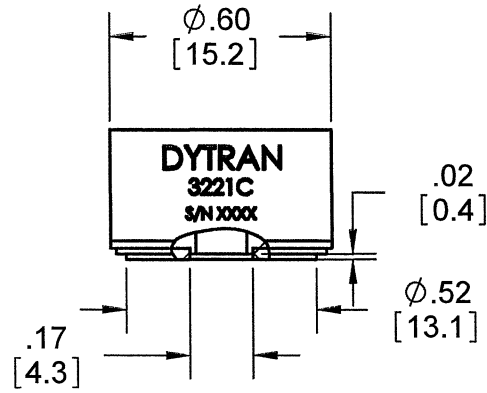
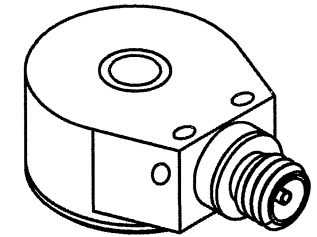

MOUNTING RECOMMENDATIONS:
CLEAN SURFACE AT LEAST $\phi .55$, FLAT TO .0001TIR
TAP 6-32 UNC-2B AT LEAST $\nabla .13$
USE SILICON GREASE, TORQUE TO 5-7LB-IN

5. MAXIMUM OPERATING TEMPERATURE: 500°F
4. MATERIAL: HOUSING - 304L/CONNECTOR - KOVAR
3. DIRECTION OF ACCELERATION FOR POSITIVE OUTPUT
2. SENSITIVITY: SEE TABLE
1. WEIGHT, MAX: 12.5 GRAMS

NOTES: UNLESS OTHERWISE SPECIFIED

CONTRACT NO.

MASTER

ONLY IF IN RED

TITLE:
**OUTLINE/INSTALLATION
DRAWING, MODEL 3221C**

SIZE	CAGE CODE	DWG. NO.	REV
A	2W033	127-3221C	A
SCALE: 2:1		SOLIDWORKS	SHEET 1 OF 1

APPROVALS		DATE
ORIG	DV	08/14/09
CHK	<i>DV</i>	<i>6/24/10</i>
APP	<i>ANJ</i>	
DO NOT SCALE DRAWING		

USED ON	NEXT ASSY	APPLICATION			
THIRD ANGLE PROJECTION USA		UNLESS OTHERWISE SPECIFIED: INTERPRET DIM & TOL PER ASME Y14.5M - 1994. REMOVE BURRS. COUNTERSINK INTERNAL THDS 90° TO MAJOR DIA. CHAM EXT THDS 45° TO MINOR DIA. THD LENGTHS AND DEPTHS ARE FOR MIN FULL THDS. THDS PER MIL-S-7742. DIMENSIONS APPLY AFTER FINISHING.			
		ALL MACHINED SURFACES: 63 TOTAL RUNOUT WITHIN .005. BREAK SHARP EDGES .005 TO .010. MACHINED FILLET RADII .005 TO .015. WELDING SYMBOLS PER AWS A2.4. ABBREVIATIONS PER MIL-STD-12.			
		UNLESS OTHERWISE SPECIFIED: DIMENSIONS ARE IN INCHES. DIMENSIONS IN BRACKETS [] ARE IN MILLIMETERS TOLERANCES ARE: INCHES METRIC ANGLES .XX ± .03 .X ± 0.8 ± 1° .XXX ± .010 .XX ± 0.25			

MODEL NUMBER 3221C2	PERFORMANCE SPECIFICATION		DOC NO. PS3221C2
	CHARGE MODE ACCELEROMETER		REV A, ECN6816, 06/04/10

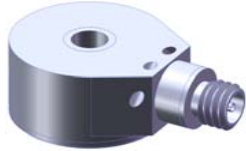

- **MINIATURE SIZE**
- **HIGH TEMPERATURE OPERATION**
- **HERMETICALLY SEALED**

PHYSICAL

Weight, Max
Mounting Provision
Connector [2]
Case Material
Sensing Element Type

ENGLISH		SI	
0.44	oz	12.5	grams
Ø.140 THRU HOLE		Ø.140 THRU HOLE	
10-32		10-32	
304L		304L	
Piezoceramic		Piezoceramic	

PERFORMANCE

Sensitivity, +/-15% [3] [4]
Range F.S
Frequency Response, +/- 10%
Mounted Resonant Frequency
Amplitude Non-Linearity
Transverse Sensitivity, Max
Strain Sensitivity @250/µ

5	pC/g	0.51	pC / m/s ²
+/-1000	g	+/-9810	m/s ²
[5] to 10000	Hz	[5] to 10000	Hz
>40	kHz	>40	kHz
1	%F.S MAX	1	%F.S MAX
2	%	2	%
0.074	g/µε	0.73	m/s ² /µε

ENVIRONMENTAL

Maximum Vibration
Maximum Shock
Temperature Range
Environmental Seal

700	g rms	6860	m/s ² rms
5000	g	49000	m/s ²
-60 to +500	°F	-51 to + 260	°C
Hermetic		Hermetic	

ELECTRICAL

Output Signal Polarity
Case Grounding
Base Grounding

Positive		Positive	
Case is grounded		Case is grounded	
Base is isolated		Base is isolated	

This family also includes:

Model	Sensitivity (pC/g)	Range F.S. (g)	Operating Temperature (°F)
3221C	10	± 500	-60 to +500

Please, refer to the performance specifications of the products in this family for detailed description.

Supplied Accessories

- 1) Model 6297 mounting assembly
- 2) Accredited calibration certificate (ISO 17025)

Notes:

- [1] Flat mounting surface for adhesive mount.
- [2] Connector , radially mounted, 10-32 coaxial
- [3] Measured at 100 Hz, 1 G RMS per ISA RP37.2.
- [4] Actual sensitivity is on a calibration certificate supplied with each instrument.
- [5] Low frequency response is depend upon the discharge time constant of the charge amplifier.
- [6] Unit can survive a intermittent exposure to 600°F MAX
- [7] In the interest of constant product improvement, we reserve the right to change specifications without notice

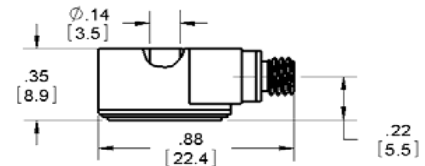
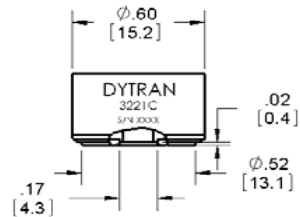
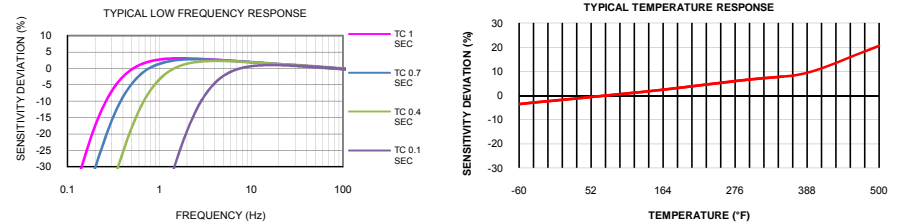

Units on the line drawing are in inches, units in brackets are in millimeters. Refer to 127-3221C for more information.



21592 Marilla Street, Chatsworth, California 91311 Phone: 818.700.7818 Fax:818.700.7880 www.dytran.com
For permission to reprint this content, please contact info@dytran.com