

ARROW INDICATES SENSE AND DIRECTION OF ACCELERATION FOR NEGATIVE-GOING OUTPUT SIGNAL

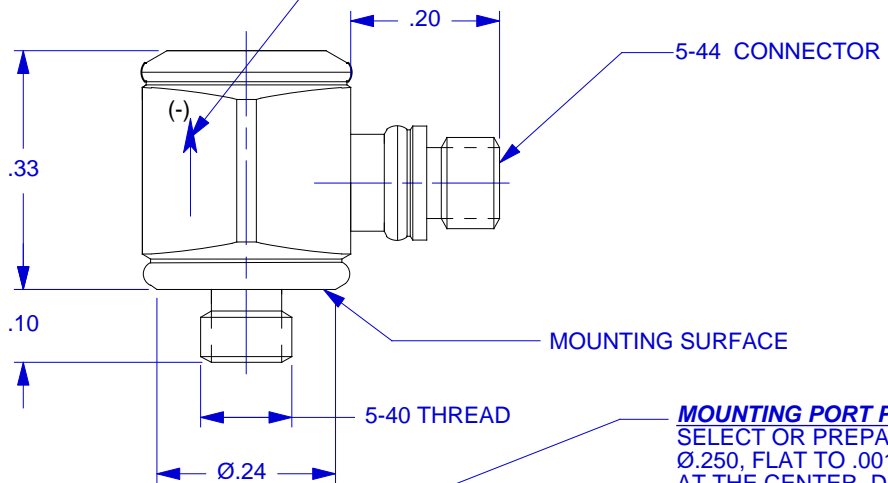

**MOUNTING PORT PREPARATION:**  
 SELECT OR PREPARE A FLAT AREA OF AT LEAST Ø.250, FLAT TO .001 TIR.  
 AT THE CENTER, DRILL #38 (Ø.101) X .150 DEEP, MIN.  
 TAP 5-40 UNC-2B X .125 DEEP, MIN.

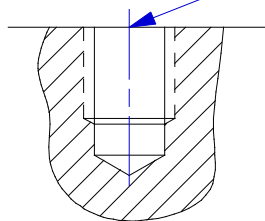

- 2. MOUNTING TORQUE ON .281 HEX: 8 TO LB.-INCHES.
- 1. WEIGHT: 2.5 GRAMS.

		CHATSORTH, CA.						
		SCALE	4X	REV	-	DATE	-	ECN
DATE		11/15/99		PART NO.		MODEL 3035C		
DRAWN	N.C.	CHECKED	R.A.	MAT'L				
APPROVED		NEXT ASSEMBLY			USED ON			
TITLE							DWG NO.	
<b>OUTLINE/INSTALLATION DRAWING,          MODEL 3035C CHARGE MODE ACCELEROMETER,          NEGATIVE OUTPUT</b>							<b>127-3035C</b>	
							SHEET 1 OF 1	



**SPECIFICATIONS  
MODEL 3035C CHARGE MODE ACCELEROMETER**

SPECIFICATION	VALUE	UNITS
<b>PHYSICAL</b>		
WEIGHT	2.5	Grams
SIZE, HEX X HEIGHT	.281 (9/32) X .33	Inches
MOUNTING PROVISION	5-40 integral stud	
CONNECTOR, RADially MOUNTED	5-44	Coaxial
MATERIAL, HOUSING AND CONNECTOR	300 Series	Stainless Steel
<b>PERFORMANCE</b>		
SENSITIVITY, NOM.[1]	2.5	pC/G
RANGE F.S.	± 500	G's
FREQUENCY RANGE, ± 15%	0.5 to 15k	Hz
RESONANT FREQUENCY, NOM.	45	kHz
LINEARITY [2]	± 1%	% F.S.
TRANSVERSE SENSITIVITY, MAX.	5	%
STRAIN SENSITIVITY	.002	G's/μσ @ 250 μσ
<b>ENVIRONMENTAL</b>		
MAXIMUM VIBRATION/SHOCK	600/3000	± G's/G's PEAK
TEMPERATURE RANGE	-100 to +400	°F
SEAL, HERMETIC	Glass-to-metal and TIG welded	
COEFFICIENT OF THERMAL SENSITIVITY	.07	%/°F
<b>ELECTRICAL</b>		
CAPACITANCE, NOM.	630	pF
OUTPUT SIGNAL POLARITY FOR ACCELERATION TOWARD TOP		Negative
CASE GROUNDING	Case is grounded to electrical power ground	

[1] Measured at 100 Hz, 1 G RMS per ISA RP 37.2.

[2] Measured using zero-based best straight-line method, % of F.S. or any lesser range.