



FEATURES

- Conceived and designed for customisation
- SMD or Through-hole Mount
- Endless Rotation (360°)
- Wide Electrical Angle (340° ± 10°)
- Extended Mechanical Life (100k cycles)
- Working Temperature Range (-40°C to +120°C)
- Low Profile (4.4 mm)
- Linearity ± 3% (standard)
- Embossed Tape or Bulk packaging
- Reflow Soldering capability
- Shaft insertable from both sides
- Polarised "T" rotor (European Home Appliance standard)
- All PT/ PTC 15 shafts compatible

STANDARD SPECIFICATIONS

Resistance values*:	5k, 10k, 100k
Tolerance:	± 30%
Nominal Power:	0.15 W @ 50°C
Linearity (absolute):	± 3%
Taper:	Linear
Mechanical Life**:	100,000 cycles
Temperature Range:	-40°C to +120°C
Mechanical Angle:	360°
Electrical Angle:	340° ± 10°
Rotational Torque:	≤ 20 mN.m
Max. Voltage:	250 VDC

(*) Others upon request

(**) 200,000 cycles version available upon request

TYPICAL APPLICATIONS

- The N15 series offers an SMD and Through Hole mount solution for the majority of **Position/Rotary Sensor** and **multi-purpose Control** applications such as:
- Automotive HVAC, Seat, Rear-view mirror actuator feedback sensors and HVAC Controls
 - Temperature Control for Boilers, Wall Heaters, Showers, Radiators, Conventional and Microwave Ovens, Freezers...
 - Timer & Function/Programme Select for Washing Machines, Dishwashers and all White Goods in general.
 - Size and Position detectors

HOW TO ORDER

N-15	T	S	103	A	3030
Series	Rotors	Mounting Method	Value	Taper	Tolerance
N-15 <small>(See note 1)</small>	T	V = Through Hole S = SMD H = Horizontal Adjust <small>(See note 4)</small>	502 = 5 K 103 = 10 K 104 = 100 K	A = Lin. <small>(See note 2)</small>	3030 = ± 30% <small>(See note 3)</small>

NOTES:

- (1) A wide variety of custom substrates available
- (2) Availability of a wide range of customised tapers and step curves
- (3) Optional precision laser-trimmed voltage divider calibration
- (4) Horizontal adjust versions will be studied case by case

Shafts are not available mounted to the potentiometer and should be ordered separately

NOTE: The information contained here should be used for reference purposes only.

N-15 T S + DRAWING NUMBER (Max. 16 digits)

This way of ordering should be used for options which are not included in the "How to order" standard and optional extras.

Wiper positioned at 50 % of the electrical angle.

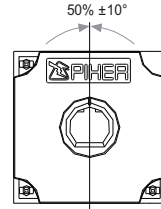

SMD MOUNT

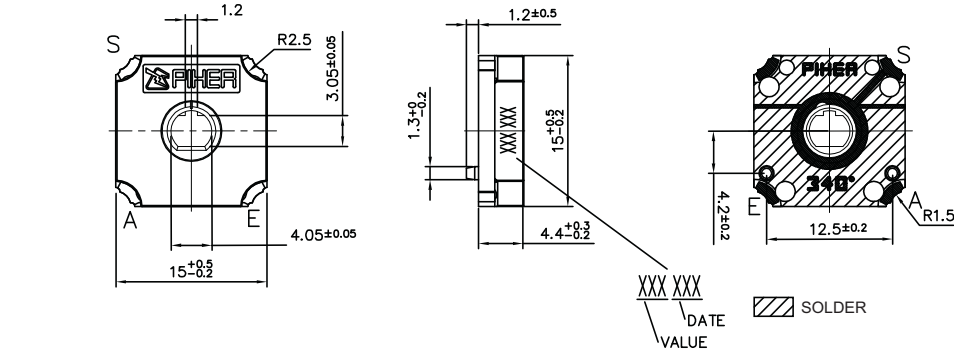

FOOT - PRINT



THROUGH HOLE MOUNT

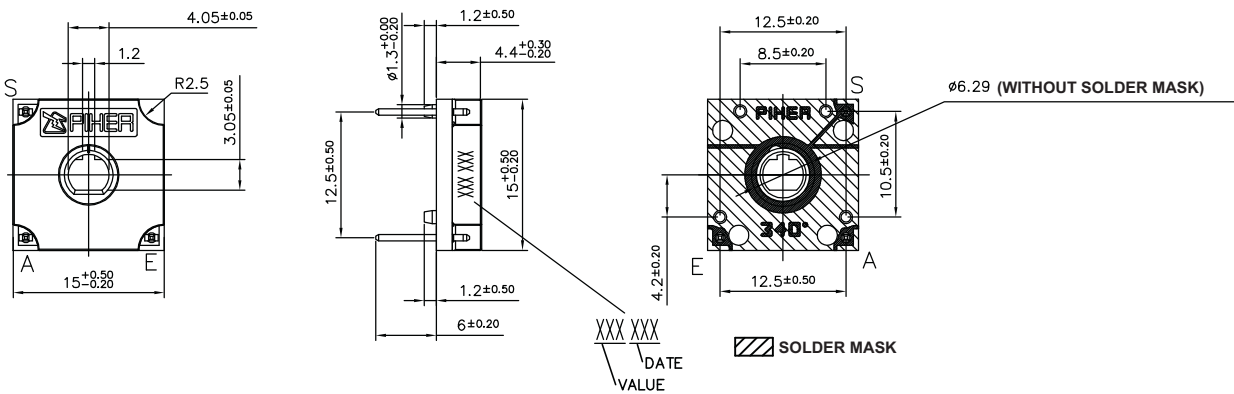

PCB HOLE LAYOUT 1

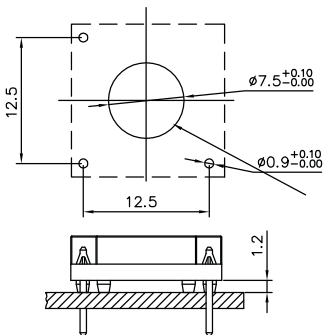

PCB HOLE LAYOUT 2

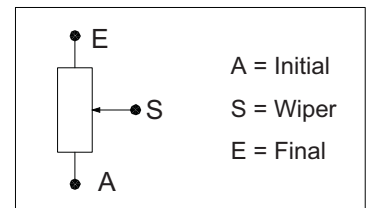
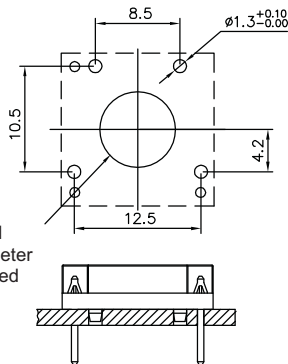

HORIZONTAL ADJUST - VERTICAL MOUNT

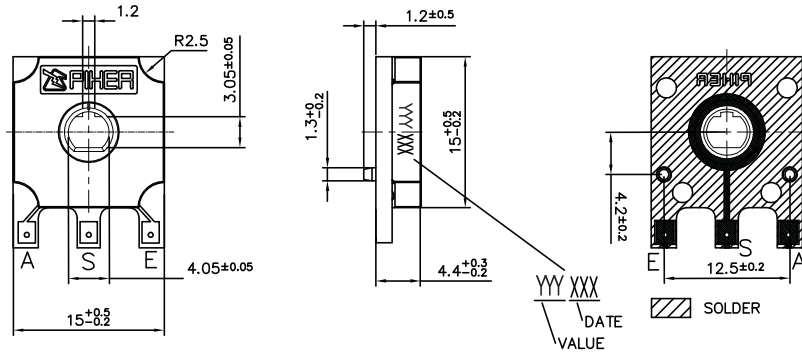

TESTS

TYPICAL VARIATIONS

ELECTRICAL LIFE	1.000 h. @ 50°C; 0.15 W	±40 %
MECHANICAL LIFE (CYCLES)	100,000 @ 20 CPM	±40 % (Rn < 100 K)
TEMPERATURE COEFFICIENT	-40°C to +120°C	±300 ppm (Rn < 100 K)
THERMAL CYCLING	10h. @ 120°C; 10h. @ -40°C	±40 %
DAMP HEAT	500 h. @ 40°C @ 95% HR	±40 %

NOTE : Out of range values may not comply these results.

PACKAGING

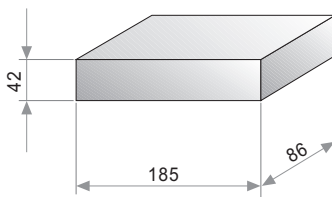

BULK

150 Units per box.
Through hole version only

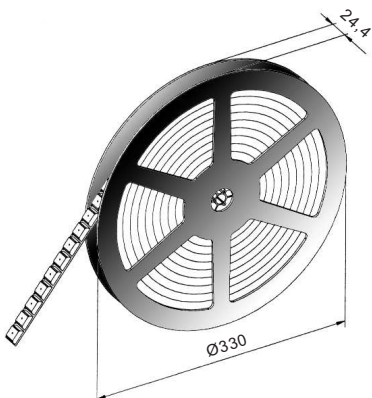

EMBOSSED TAPE

500 Units per Reel
SMD version only

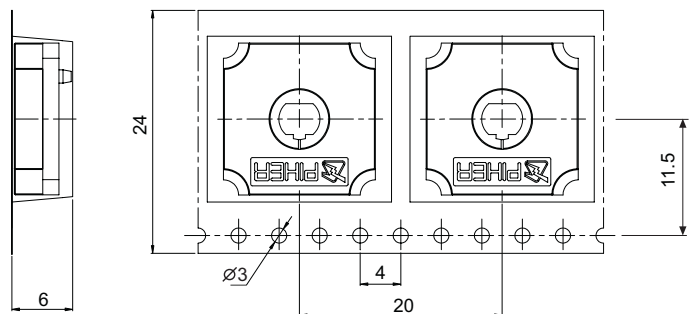

POWER RATING CURVE

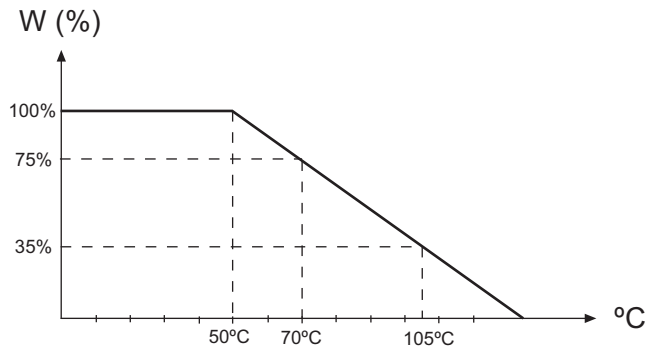

RECOMMENDED CONNECTIONS

Recommended connection scheme for Piher's position sensors (voltage divider)

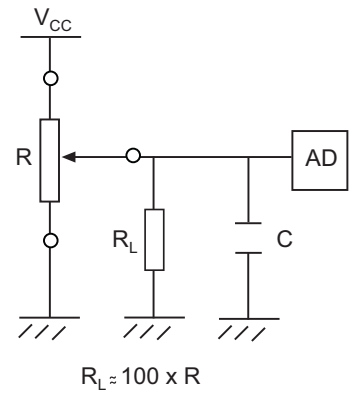

RECOMMENDED REFLOW PROFILE (SMD types)

SnPb Reflow Profile

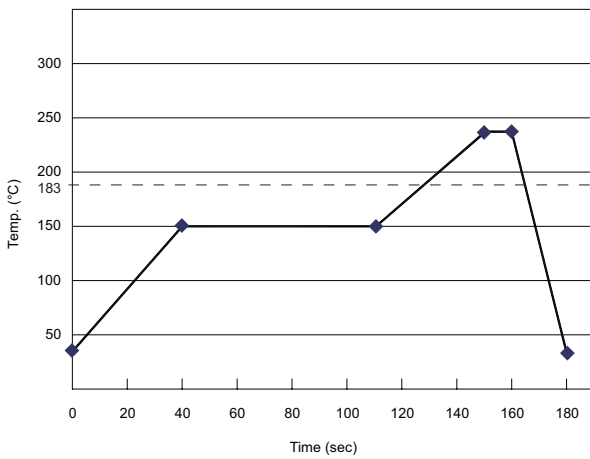

Lead Free Reflow Profile

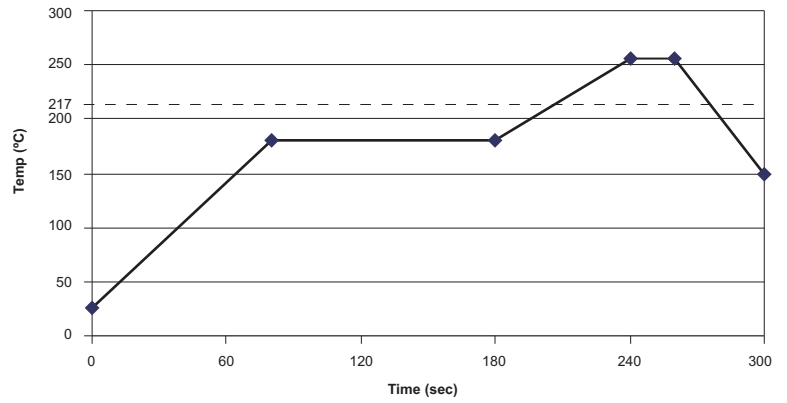

SHAFTS

Hollow model shafts

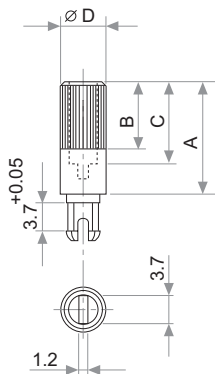

FIG.	A	B	C	D	Ref.
1	12	9	8	6	5272
2	19	9	15	6	5214
5	9.5	6.5	5.5	6	5208
9	35	9	15	6	5216
10	37.8	9	33.8	6	5218
11	35	25	15	6	5209
13	7.8	4.8	3.8	6	5265

Solid model shafts

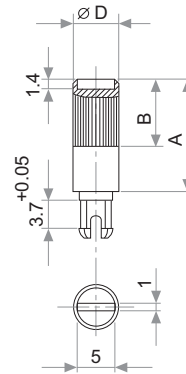

FIG.	A	B	D	Ref.
6	15	9	6	5219
7	16.8	9	6	5220
8	25.3	9	6	5207
12	46	5	6	5227

Slot (1 x 1.4) perpendicular to wiper position. Fig. 12 slot is on line with wiper position.

A = Length (FRS); B=Knurling length; C=Hollow depth; D=Shaft diameter; FRS=From rotor surface

Other shafts

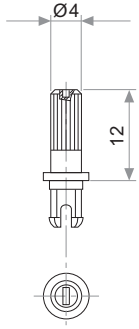

Fig. 3 / Ref. 5372

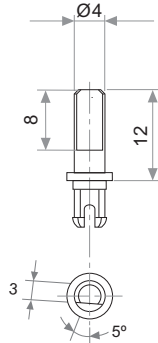

Fig. 15 / Ref. 5217

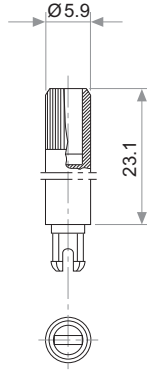

Fig. 17 / Ref. 5210

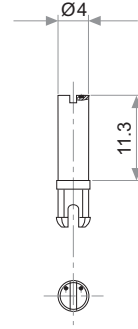

Fig. 18 / Ref. 5271

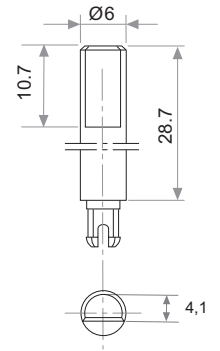

Fig. 19 / Ref. 6032*

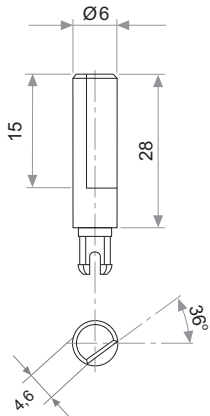

Fig. 20 / Ref. 5369*

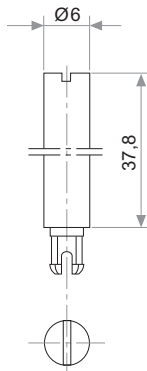

Fig. 21 / Ref. 6031*

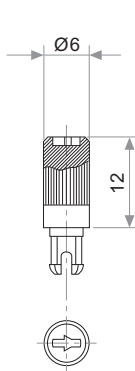

Fig. 22 / Ref. 6029

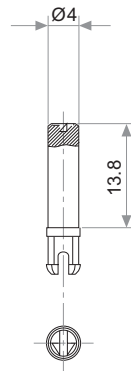

Fig. 23 / Ref. 6022

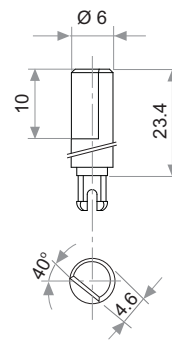

Fig. 29 / Ref. 6162

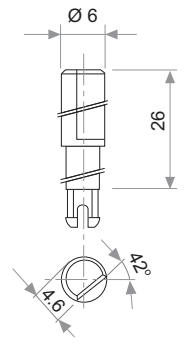

Fig. 25 / Ref. 6059

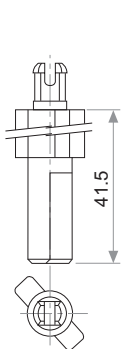

Fig. 27 / Ref. 5268*

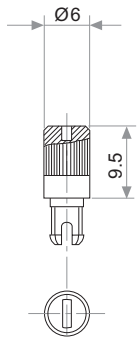

Fig. 28 / Ref. 6055

* Not available in self extinguishable plastic