

PROPRIETARY AND CONFIDENTIAL

THE INFORMATION CONTAINED IN THIS DRAWING IS THE SOLE PROPERTY OF DYTRAN INSTRUMENTS INC. ANY REPRODUCTION IN PART OR AS A WHOLE WITHOUT THE WRITTEN PERMISSION OF DYTRAN INSTRUMENTS, INC. IS PROHIBITED

REVISIONS

REV	ECN	DESCRIPTION	BY/DATE	CHK	APPR
C	5902	IS: 6580 WAS: 6728	RA, 04/03/09	De	As

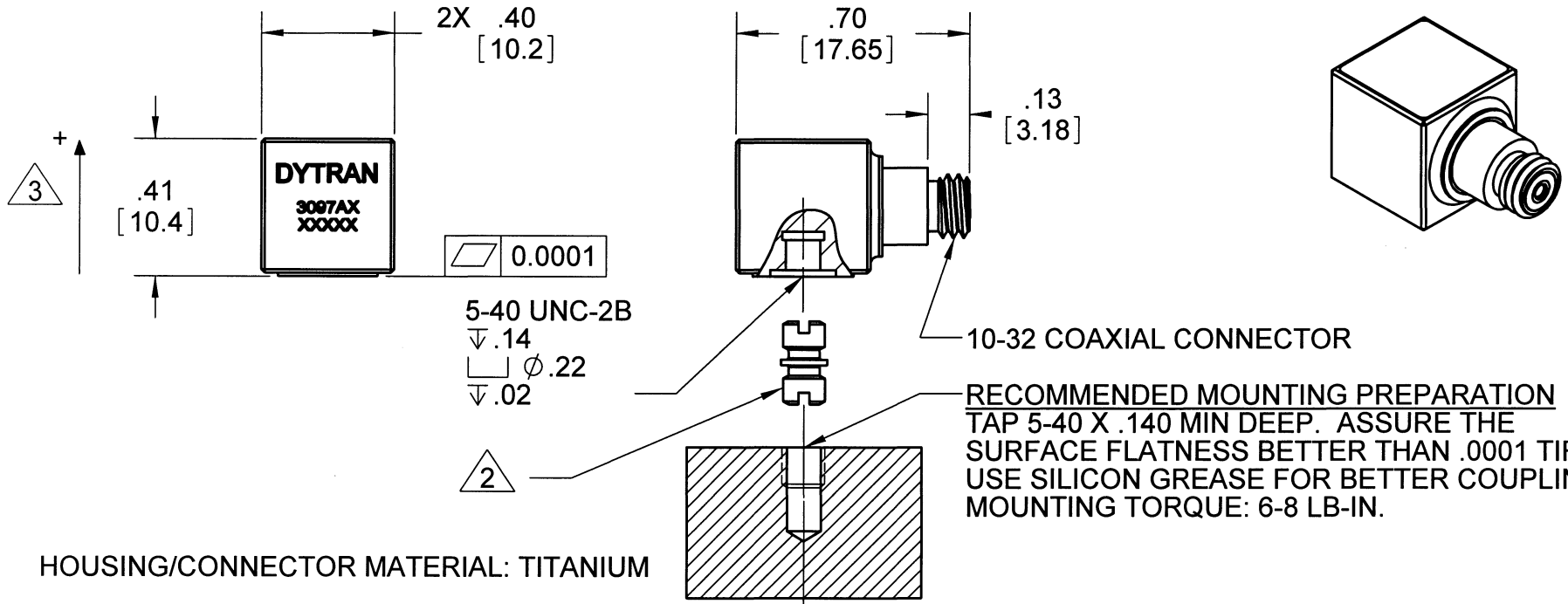

- 5. HOUSING/CONNECTOR MATERIAL: TITANIUM
 - 4. WEIGHT: 4.3 GMS
 - 3. ARROW DESIGNATES UNIT'S POLARITY
 - 2. MOUNTING STUD 6580 (5-40 TO 5-40) SUPPLIED
 - 1. DELETED
- NOTES: UNLESS OTHERWISE SPECIFIED

MODEL	SENSITIVITY
3097A3	500mV/g
3097A2	100mV/g
3097A1	10mV/g

3097A

APPLICATION

THIRD ANGLE PROJECTION USA

UNLESS OTHERWISE SPECIFIED:
 INTERPRET DIM & TOL PER ASME Y14.5M - 1994.
 REMOVE BURRS.
 COUNTERSINK INTERNAL THDS 90° TO MAJOR DIA.
 CHAM EXT THDS 45° TO MINOR DIA.
 THD LENGTHS AND DEPTHS ARE FOR MIN FULL THDS.
 THDS PER MIL-S-7742.
 DIMENSIONS APPLY AFTER FINISHING.

ALL MACHINED SURFACES. TOTAL RUNOUT WITHIN .005.
 BREAK SHARP EDGES .005 TO .010.
 MACHINED FILLET RADII .005 TO .015.
 WELDING SYMBOLS PER AWS A2.4.
 ABBREVIATIONS PER MIL-STD-12.

UNLESS OTHERWISE SPECIFIED:
 DIMENSIONS ARE IN INCHES.
 TOLERANCES ARE:

DECIMALS	ANGLES
.XX ± .010	± 1°
.XXX ± .005	

MATERIAL

FINISH

DO NOT SCALE DRAWING

CONTRACT NO.

APPROVALS		DATE
ORIG	DV	09/11/08
CHK	DV	09/11/08
APP	DV	09/11/08
APP		

DYTRAN INSTRUMENTS, INC. MASTER COPY WITH TA ONLY IF IN RED

TITLE: **OUTLINE/ INSTALLATION DRAWING, 3097A SERIES**

SIZE A	CAGE CODE 2W033	DWG. NO. 127-3097A	REV C
SCALE: 2:1	SOLIDWORKS	SHEET 1 OF 1	

Model Number 3097A3	PERFORMANCE SPECIFICATIONS	DOC NO PS3097A3
IEPE ACCELEROMETER		REV D, EGN 7642, 06/29/11

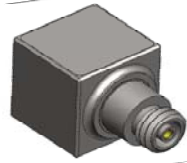

- **MINIATURE SIZE**
- **HERMETICALLY SEALED**
- **EXCELLENT LINEARITY**

This family also includes:

Model	Sensitivity (mV/g)	Frequency Response ±5%, (Hz)	Time Constant (Sec)	Operating Temp (°F)
3097A1	10	0.3 to 5000	1.5 to 2.5	-60 to 200
3097A2	100	0.3 to 5000	1.5 to 2.5	-60 to 180

Refer to the performance specifications of the products in this family for detailed description

Supplied Accessories:

- 1) Accredited calibration certificate (ISO 17025)
- 2) Model 6580 mounting stud (5-40 to 5-40), qty 1

Notes:

- [1] Coaxial, 10-32 connector. Mates with Dytran cable Model 6010AXX or 6011AXX
- [2] Measured at 100Hz, 1 Grms per ISA RP 37.2.
- [3] Measure using zero-based straight line method, % of F.S. or any lesser range.
- [5] Do not apply power to this system without current limiting, 20 mA MAX. To do so will destroy the IC charge amplifier.
- [6] In the interest of constant product improvement, we reserve the right to change specifications without notice.

PHYSICAL

Weight
 Connector [1]
 Mounting Provision
 Material, Housing/Connector
 Sensing Element
 Element Style

Type
 Tapped Hole

ENGLISH		SI	
0.15	oz	4.3	grams
10-32		10-32	
5-40 UNC-2B		5-40 UNC-2B	
TITANIUM		TITANIUM	
CERAMIC		CERAMIC	
PLANAR SHEAR		PLANAR SHEAR	

PERFORMANCE

Sensitivity, ±5% [2]
 Range for ± 5 Volts Output
 Frequency Response, ±5%
 ±15%
 Resonant Frequency
 Broad Band Resolution
 Spectral Noise
 1Hz
 10Hz
 100Hz
 1000Hz
 10000Hz
 Linearity [2]
 Maximum Transverse sensitivity
 Strain Sensitivity @ 250µε
 Phase Response ±5°

500	mV/G	51	mV/m/s ²
10	G peak	98	m/s ²
0.3 to 5000	Hz	0.3 to 5000	Hz
0.15 to 10,000	Hz	0.15 to 10,000	Hz
> 35	kHz	> 35	kHz
0.0003	G rms	0.003	m/s ² rms
0.00005	Grms/v(Hz)	0.000	m/s ² rms/v(Hz)
0.00001	Grms/v(Hz)	0.0001	m/s ² rms/v(Hz)
0.00000	Grms/v(Hz)	0.00004	m/s ² rms/v(Hz)
0.000002	Grms/v(Hz)	0.00002	m/s ² rms/v(Hz)
0.000002	Grms/v(Hz)	0.00002	m/s ² rms/v(Hz)
±1	% F.S.	±1	% F.S.
5	%	5	%
0.002	G/µε	0.02	m/s ² /µε
5 to 3000	Hz	5 to 3000	Hz

ENVIRONMENTAL

Maximum Vibration
 Maximum Shock
 Temperature Range
 Seal

200	G peak	1962	m/s ² peak
5000	G peak	49050	m/s ² peak
-60 to 150	°F	-51 to 65	°C
HERMETIC		HERMETIC	

ELECTRICAL

Supply Current Range [3]
 Compliance Voltage Range
 Output Impedance, Typ
 Bias Voltage
 Discharge Time Constant

2 to 20	mA	2 to 20	mA
+18 to +30	Volts	+18 to +30	Volts
100	Ω	100	Ω
+11 to +13	VDC	+11 to +13	VDC
1.5 to 2.5	Sec	1.5 to 2.5	Sec

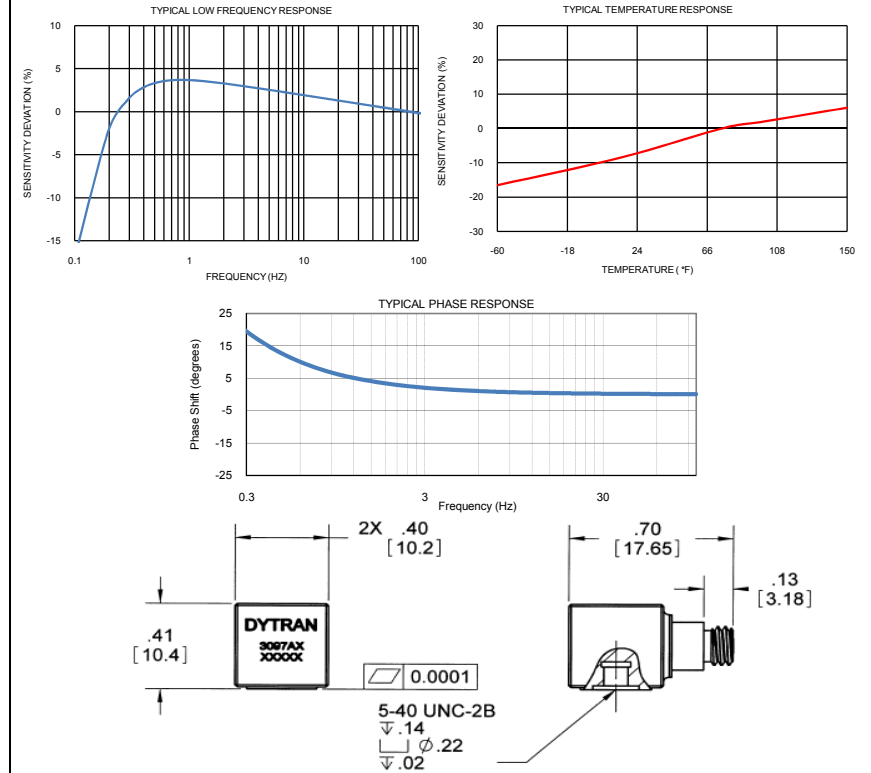

Units on the line drawing are in inches, units in brackets are in millimeters. Refer to 127-3097A for more information.



21592 Marilla Street, Chatsworth, California 91311 Phone: 818.700.7818 Fax: 818.700.7880 www.dytran.com
 For permission to reprint this content, please contact info@dytran.com