

**PROPRIETARY AND CONFIDENTIAL**

THE INFORMATION CONTAINED IN THIS DRAWING IS THE SOLE PROPERTY OF DYTRAN INSTRUMENTS INC. ANY REPRODUCTION IN PART OR AS A WHOLE WITHOUT THE WRITTEN PERMISSION OF DYTRAN INSTRUMENTS, INC. IS PROHIBITED

**REVISIONS**

REV.	ECN	DESCRIPTION	BY/DATE	CHK	APPR
B	5022	DELETED "TYPICAL INSTALLATION " VIEW	JS 01/21/08	A.S.	A.S.
C	5057	IS:1/4-28 UNF-2A FOR 3086A1 THRU A6 10-32 UNF-2A FOR 3086A1T THRU A6T WAS: 1/4-28 UNF-2A	RA, 2/13/08	JS	JS
D	5498	ADDED WIRES & O RING	JS 10/16/08	AS	DV

SIGNAL GROUND (BROWN)

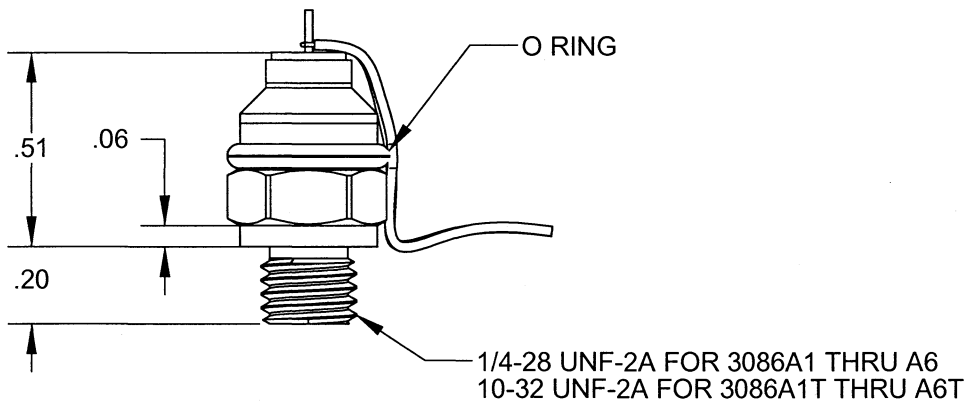
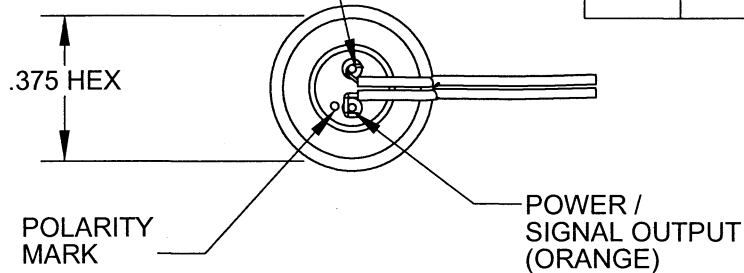

2. HOUSING MATERIAL: TITANIUM ALLOY

1. RECOMMENDED MOUNTING TORQUE:  
30 LB-IN

DRILL HOLE SIZE	TOLERANCE	UNLESS OTHERWISE SPECIFIED: INTERPRET DIM & TOL PER ASME Y14.5M - 1994. REMOVE BURRS. COUNTERSINK INTERNAL THDS 90° TO MAJOR DIA. CHAM EXT THDS 45° TO MINOR DIA. THD LENGTHS AND DEPTHS ARE FOR MIN FULL THDS. THDS PER MIL-S-7742. DIMENSIONS APPLY AFTER FINISHING. ALL MACHINED SURFACES. TOTAL RUNOUT WITHIN .005. BREAK SHARP EDGES .005 TO .010. MACHINED FILLET RADII .005 TO .015. WELDING SYMBOLS PER AWS A2.4. ABBREVIATIONS PER MIL-STD-12.
.0135 THRU .125	+ .004 / - .001	
.1260 THRU .250	+ .005 / - .001	
.2510 THRU .500	+ .006 / - .001	
.5010 THRU .750	+ .008 / - .001	
.7510 THRU 1.000	+ .010 / - .001	
1.001 THRU 2.000	+ .012 / - .001	

THIRD ANGLE PROJECTION  
USA

UNLESS OTHERWISE SPECIFIED: DIMENSIONS ARE IN INCHES. TOLERANCES ARE:	
DECIMALS .XX ± .010 .XXX ± .005	ANGLES ± 1°
MATERIAL	APPROVALS
FINISH	DATE
DO NOT SCALE DRAWING	

CONTRACT NO.	
ORIG	PML 3/28/07
CHK	JS 2/15/08
APP	DV 10/17/08
APP	

**DYTRAN INSTRUMENTS, INC.** Chatsworth, CA

**MASTER ONLY IF IN RED**

TITLE: **OUTLINE DRAWING, 3086A**

SIZE <b>A</b>	CAGE CODE <b>2W033</b>	DWG. NO. <b>127-3086A</b>	REV <b>D</b>
SCALE: 4:1	SOLIDWORKS	SHEET 1 OF 1	



# Dynamic Transducers and Systems

21592 Marilla St. • Chatsworth, CA 91311 • Phone 818-700-7818  
 www.dytran.com • e-mail: info@dytran.com

## SPECIFICATIONS, SERIES 3086A/AT IEPE HIGH SHOCK ACCELEROMETERS

### SPECIFICATIONS BY MODEL

MODEL	RANGE F.S. (g)	MAXIMUM SHOCK (g)	SENSITIVITY (NOM)[1] (mV/g)	ELECTRICAL NOISE (g)	NATURAL FREQUENCY (kHz)	ISOLATION CUP RESONANCE (kHz)
3086A1/A1T	70,000	100,000	0.05	0.014	100	45
3086A2/A2T	50,000	100,000	0.1	0.007	100	45
3086A3/A3T	20,000	100,000	0.25	0.0028	100	45
3086A4/A4T	10,000	50,000	0.5	0.0014	100	45
3086A5/A5T	5000	50,000	1.0	0.0007	100	45
3086A6/A6T	2500	50,000	2.0	0.0035	100	45

### COMMON SPECIFICATIONS

SPECIFICATION	VALUE	UNITS
DISCHARGE TIME CONSTANT, NOM.	1.0	SECOND
LOW FREQUENCY -3db POINT, NOM.	.16	Hz
LOW FREQUENCY -5% POINT	.50	Hz
FREQUENCY RESPONSE, ±10%	.35 to 10000	Hz
LINEARITY [2]	±1	% F.S.
TRANSVERSE SENSITIVITY, MAXIMUM	3.0	%
OUTPUT IMPEDANCE, NOM.	100	OHMS
OUTPUT VOLTAGE BIAS, NOM.	+8.5	VDC
SUPPLY CURRENT RANGE [3]	2 to 20	mA
COMPLIANCE (SUPPLY) VOLTAGE RANGE [4]	+18 to +20	VDC
OPERATING TEMPERATURE RANGE	-60 to +250	°F
SIZE (HEX x HEIGHT) [4]	3/8 x .64	INCHES
WEIGHT	3.5	GRAMS
CONNECTOR, TOP MOUNTED	SOLDER PINS	
MATERIAL, HOUSING/CONNECTOR	TITANIUM ALLOY	
MOUNTING PROVISION, 3086A/3086AT	1/4-28 INTEGRAL STUD/10-32 MOUNTING STUD	
ENVIRONMENTAL SEAL	HERMETIC	
ISOLATION, CASE TO MOUNTING SURFACE, MIN	10	MΩ

RECOMMENDED CABLE: DYTRAN PART NO. 128-6869AXX (XX DENOTES LENGTH IN FEET)

[1] Measured by impacting against calibrated force sensor. NIST traceable.

[2] Percent of full scale or any lesser designated full scale range, zero-based best fit straight line method.

[3] Power only with Dytran or Dytran approved current source type power unit. Do not supply power without current limiting. You will destroy the integral electronics. This will void the warranty.

[4] Height measured from mounting surface to top of connector. Integral mounting studs are .20 in. long.