

DYTRAN PROPRIETARY AND CONFIDENTIAL
 THE INFORMATION CONTAINED IN THIS DRAWING IS THE SOLE PROPERTY OF
 DYTRAN INSTRUMENTS, INC. AND ANY REPRODUCTION IN PART OR AS A
 WHOLE OR ANY OTHER DISSEMINATION OF THIS INFORMATION WITHOUT THE
 WRITTEN PERMISSION OF DYTRAN INSTRUMENTS, INC. IS PROHIBITED.

REV	ECN	DESCRIPTION	BY/DATE	CHK	APPR
B	7725	UPDATED MARKING, CABLE VIEW	RLA 08/03/11	<i>RLA</i>	<i>ALS</i>

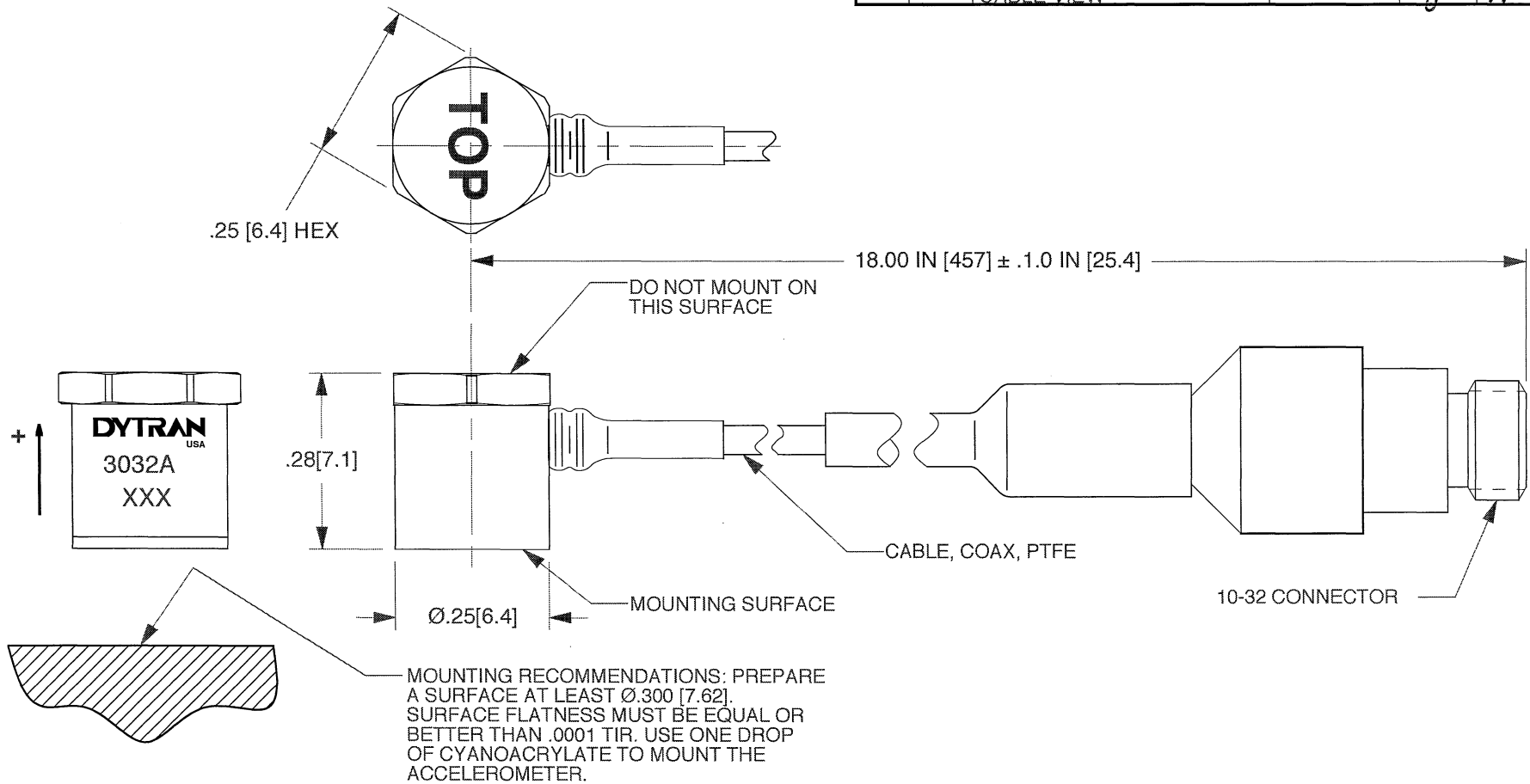

3. HOUSING MATERIAL: TITANIUM

2. WEIGHT (LESS CABLE): 1.5 GRAMS

1. TO REMOVE, (UN-INSTALL) TORQUE GENTLY ON HEX UNTIL ADHESIVE JOINT FAILS IN SHEAR. DO NOT STRIKE TO REMOVE.

NOTES: UNLESS OTHERWISE SPECIFIED

USED ON	NEXT ASSY
APPLICATION	
THIRD ANGLE PROJECTION USA	

UNLESS OTHERWISE SPECIFIED:
 INTERPRET DIM & TOL PER ASME
 Y14.5M-1994. REMOVE BURRS
 COUNTERSINKS INTERNAL THDS 90°
 TO MAJOR DIA CHAM EXT THDS 45°
 TO MAJOR DIA. THD LENGTHS AND
 DEPTHS ARE FOR THDS PER MIL-S-
 7742.
 DIMENSIONS APPLY AFTER
 FINISHING.

ALL MACHINED SURFACES ⁶³
 TOTAL RUNOUT WITHIN .005 BREAK
 SHARP EDGES .005 TO .010 MACHINE
 FILLET RADI .005 TO .015. WELDING
 SYMBOLS PER AWS A2.4
 ABBREVIATIONS PER MIL-STD-12

CONTRACT NO		
UNLESS OTHERWISE SPECIFIED DIMENSIONS ARE IN INCHES. DIMENSION IN BRACKETS [] ARE IN MILLIMETERS. TOLERANCES ARE:		
INCHES	METRIC	ANGLES
.XX ± .03	.X ± 0.8	± 1°
.XXX ± .010	.XX ± 0.25	
FINISH		
DO NOT SCALE DRAWING		

MASTER

ONLY IF IN RED

CHATSWORTH, CA.

SCALE 4X	DESIGN NC	DATE 10/23/98			
DRAWN NC	DATE 10/23/98	PART NO.			
CHECKED R.A.	DATE 10/23/98	MAT'L			REV B
APPROVED N.C.	DATE 10/23/98	NEXT ASSEMBLY		USED ON	

**OUTLINE/INSTALLATION DRAWING,
MODEL 3032A**

DWG NO. **127-3032A**

SHEET 1 OF 1



SPECIFICATIONS

MODEL 3032A MINIATURE QUARTZ SHEAR LIVM ACCELEROMETER

SPECIFICATION	VALUE	UNITS
PHYSICAL		
WEIGHT, LESS CABLE	1.5	GRAMS
WEIGHT, INCLUDING CABLE	5.6	GRAMS
SIZE (HEX x HEIGHT)	.25 x .28	INCHES
MOUNTING PROVISION	ADHESIVE MOUNT	
CONNECTOR, COAXIAL, MOUNTED AT END OF 18 IN CABLE	10-32, UNF-2A	JACK
CASE /CAP MATERIAL	TITANIUM	
ELEMENT TYPE	QUARTZ SHEAR	
PERFORMANCE		
SENSITIVITY, +/-10% [1]	10	mV/G
RANGE F.S. FOR +/- 5 VOLTS OUT	+/- 500	G's
FREQUENCY RESPONSE, +/- 10%	1 to 10,000	Hz
FREQUENCY RESPONSE, +/- 3db	.66 TO 12,000	Hz
MOUNTED RESONANT FREQUENCY, NOM.	80	kHz
EQUIVALENT ELECTRICAL NOISE (RESOLUTION)	.007	G, RMS
AMPLITUDE NON-LINEARITY (ZERO BASED BEST FIT ST.LINE METHOD)	2.0	% F.S., MAX.
TRANSVERSE SENSITIVITY, MAX.	5	PERCENT
STRAIN SENSITIVITY	.001	G's PER MICROSTRAIN @ 250/ $\mu\sigma$
ENVIRONMENTAL		
MAXIMUM VIBRATION	1000	G's, RMS
MAXIMUM SHOCK	1500	G's, PEAK
TEMPERATURE RANGE	-60 TO +250	$^{\circ}$ F
THERMAL COEFFICIENT OF SENSITIVITY	0.06	%/ $^{\circ}$ F
SEAL	EPOXY/WELDED	
ELECTRICAL		
EXCITATION (COMPLIANCE) VOLTAGE RANGE	+20 to +30	VDC
EXCITATION CURRENT RANGE	2 to 20	mA
OUTPUT IMPEDANCE, NOM.	100	OHMS
OUTPUT BIAS VOLTAGE	7.0 to 9.0	VDC
DISCHARGE TIME CONSTANT, MIN.	0.5	SEC.
OUTPUT SIGNAL POLARITY FOR ACCELERATION TOWARD TOP	POSITIVE GOING	

[1] MEASURED AT 1 G RMS AT 100 HZ PER ISA RP 37.2

[2] A CALIBRATION CERTIFICATE TRACEABLE TO **NIST** IS SUPPLIED WITH EACH INSTRUMENT.