

Model 1700 Flange Load Cell

Why the Interface Model 1700 Flange Load Cell is the best in class:

- Standard flange design mounts directly to cylinders
- Proprietary Interface temperature compensated strain gages
- Performance to .05%
- Eccentric load compensated
- .0008%/°F (.0015%/°C) temp. effect on output
- Low deflection
- Shunt calibration
- Barometric compensation
- Tension & compression



STANDARD CONFIGURATIONS

- 10 ft Integral Cable (17xxAJ-nn)
- <or> PC04E-10-6P Standard Connector (17xxAF-nn)
- <or> PT02E-10-6P Bayonet Connector (17xxACK-nn)

OPTIONS* PAGE 169

- Integral 10 ft Cable
- Bayonet Connector
- Multiple Bridge
- Standardized Output
- Connector Protection
- Overload Protection
- See Transducer Electronic Data Sheet (TEDS) Page 149

ACCESSORIES* PAGE 172

Instrumentation

*See appendix for more technical information

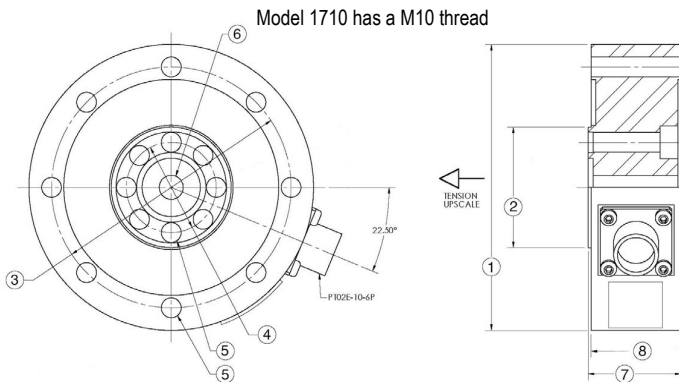

SPECIFICATIONS

ACCURACY – (MAX ERROR)	
Nonlinearity–% FS	±0.04
Hysteresis–% FS	±0.03
Nonrepeatability–% RO	±0.01
Creep, in 20 min–%	±0.025
TEMPERATURE	
Compensated Range–°F	15 to 115
Compensated Range–°C	-10 to 45
Operating Range–°F	-65 to 200
Operating Range–°C	-55 to 90
Effect on Output–%/°F – MAX	±0.0008
Effect on Output–%/°C – MAX	±0.0015
Effect on Zero– % RO/°F – MAX	±0.0008
Effect on Zero– % RO/°C – MAX	±0.0015
ELECTRICAL	
Rated Output–mV/V (nominal)	2.0
Zero Balance–%RO	±1.0
Bridge Resistance–Ohm (nominal)	350 ±3.5
Excitation Voltage–MAX	20 VDC
Insulation Resistance–Megohm	5000
MECHANICAL	
Calibration	Tension
Safe Overload–% CAP	±150 (Model 1710) ±300 (Model 1720 & 1730)
Cable Length–ft	5

SPECIFICATIONS

See Drawing	MODEL					
	*1710		1720		1730	
	CAPACITY					
	US (lbf)	Metric (kN)	US (lbf)	Metric (kN)	US (lbf)	Metric (kN)
	550, 1.1K	2.5kN, 5kN	2.2K, 4.5K	10kN, 20kN	11K, 14K	50kN, 63kN
	inch	mm	inch	mm	inch	mm
(1)	3.03	77.0	3.74	95.0	3.98	101.1
(2)	1.07	23.3	1.57	39.9	1.57	39.9
(3)	2.63	67.0	3.15	80.0	3.39	86.1
(4)	0.76	20.0	1.18	29.9	1.18	29.9
(5)	0.21	5.3	0.26	6.6	0.26	6.6
	6 places			8 places		
(6)	0.50	M10x1	0.315	8H9	0.315	8H9
(7)	1.14	29.0	1.22	31.0	1.22	31.0
(8)	1.06	27.0	0.04	1.0	0.04	1.0

*Consult factory for model 1710 drawing